

TABLE OF CONTENTS

<u>Paragraph</u>		<u>Page</u>
1	Description of Equipment	1
2	Installation	1
3	Operating Instructions	2
4	Maintenance	2
5	Principles of Operation	4
6	Parts List	5

LIST OF ILLUSTRATIONS

<u>Figure</u>		<u>Page</u>
1	Remote RF Power Indicator , AX628	0
2	Electrical Interconnections	1
3	Front and Rear Panel Component Locations	3
4	Schematic Diagram	6



Figure 1. Remote RF Power Indicator, AX628

1. DESCRIPTION OF EQUIPMENT.

Remote RF Power Indicator, AX628 (figure 1) is a power output monitoring meter unit.

The AX628 panel meter is switch selectable, providing selection for monitoring either the forward or reflected power output of an associated transmitter.

2. INSTALLATION

The AX628 measures 1-3/4-inches high with a 19-inch wide front panel, suitable for mounting into any standard width equipment rack or console.

The unit is thoroughly checked and tested at the factory prior to shipment. Upon receipt of the equipment, unpack it carefully and inspect for damage that may have occurred in transit.

With respect to damage to the equipment for which the carrier is liable, the Technical Materiel Corporation will assist in describing methods of repair and the furnishing of replacement parts.

Refer to the associated system manual for electrical connection details. See figure 2 for typical interconnections.

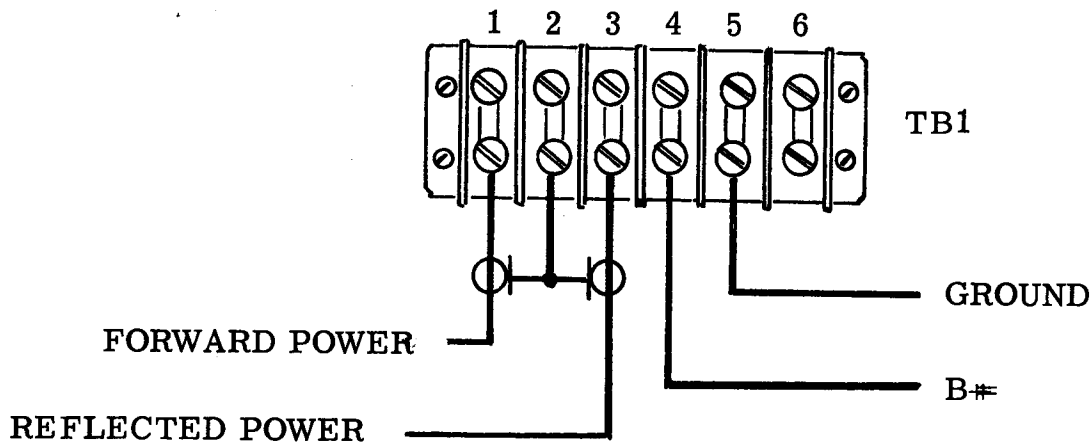

Figure 2. Electrical Interconnections

3. OPERATING INSTRUCTIONS.

The AX628 contains one operating control: a METER toggle switch. Setting the METER toggle switch to either the FORWARD or REFLECTED position will enable the front panel POWER OUTPUT meter to indicate the selected power output reading.

The POWER OUTPUT meter is calibrated in kilowatts (0 to 5.0). The associated METER switch is a momentary contact, DPDT, center-off toggle switch.

See figure 3 for front and rear panel mounted components.

4. MAINTENANCE.

Maintenance of the AX628 requires nothing more than observing for unit cleanliness, secure interconnections and probable component replacement. The rear panel mounted potentiometer R1 is a factory-adjusted component and should not be tampered with. When replacing components, refer to the parts list in section 6 for proper component replacement types and part numbers. See figure 3 for unit component locations and figure 4 for schematic diagram presentation.

5. PRINCIPLES OF OPERATION

The main function of the AX628 circuitry is to apply either the forward power output or the reflected power output of an associated receiver, to the unit kilowatt calibrated meter. This is accomplished by use of a momentary-contact, center-off DPDT toggle switch S1. Setting the toggle switch to either position, FORWARD or REFLECTED, applied that selected input through a factory-adjusted potentiometer R1 to the panel meter M1. Meter M1 will indicate the kilowatt level of the applied voltage; the meter factory calibrated by adjustment of R1.

The associated transmitter's forward and reflected power outputs are applied to the AX628 via terminal board TB1, terminals 3 and 1 respectively, with terminal 2 as common.

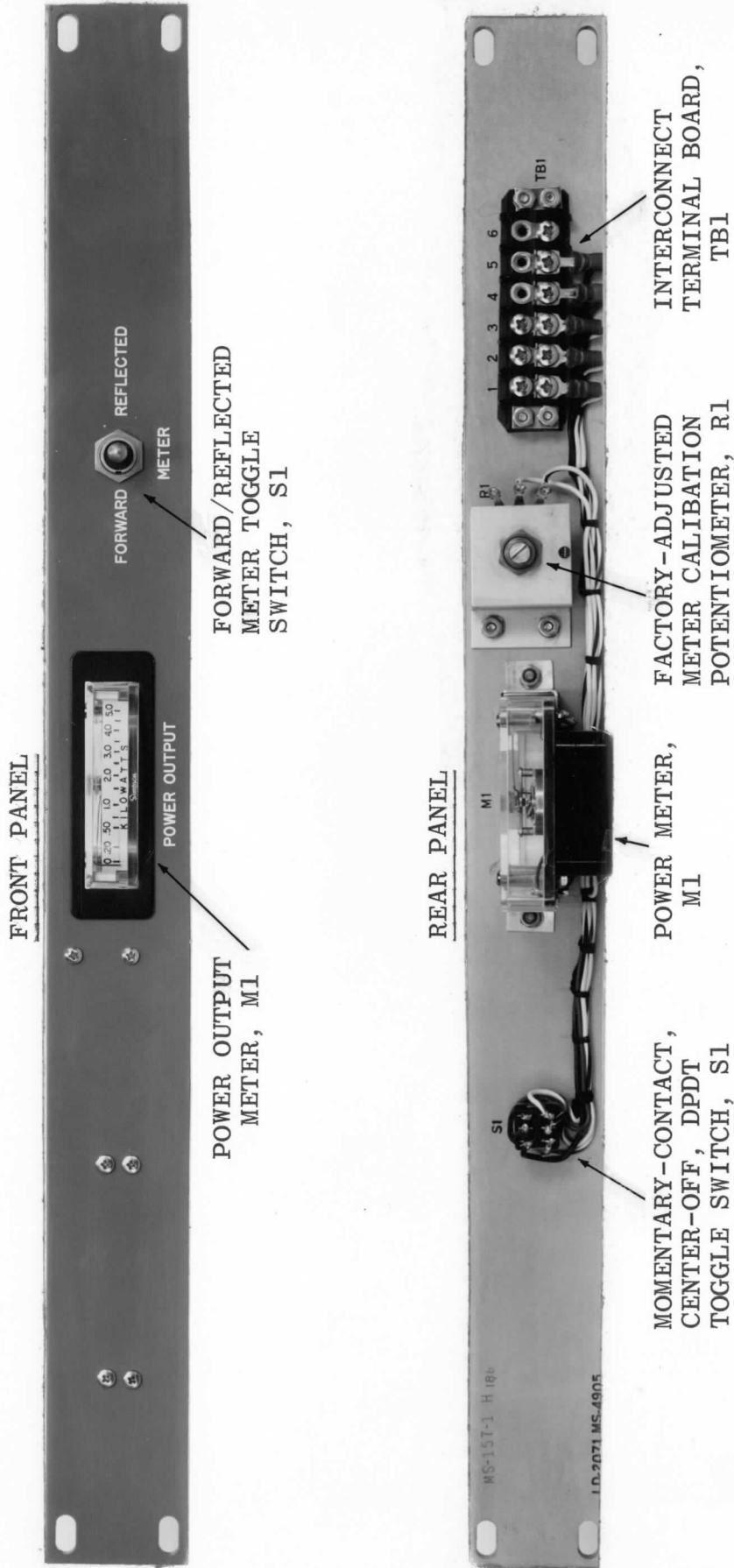

Figure 3. Front and Rear Panel Component Locations

6. PARTS LIST

The parts list presented in this section is a cross-reference list of parts identified by a reference designation and TMC part number. In most cases, parts appearing on schematic diagrams are assigned reference designations in accordance with MIL-STD-16. Wherever practicable, the reference designation is marked on the equipment, close to the part it identifies. In most cases, mechanical and electro-mechanical parts have TMC part numbers stamped on them.

To expedite delivery when ordering any part, specify the following:

- a. Reference symbol.
- b. Description as indicated in parts list.
- c. TMC part number.
- d. Model and serial numbers of the equipment containing the part being replaced; this can be obtained from the equipment nameplate.

For replacement parts not covered by warranty (refer to warranty sheet in front of manual), address all purchase orders to:

The Technical Materiel Corporation
Attention: Sales Department
700 Fenimore Road
Mamaroneck, New York

REF SYMBOL	DESCRIPTION	TMC PART NUMBER
M1	METER, POWER	MR191-3
R1	RESISTOR, VARIABLE, COMPOSITION: 1,000 ohms, +10%; 2 watts.	RV4NAYSB-102AY
S1	SWITCH, TOGGLE: DPDT; momentary contact, center off.	ST107SX
TB1	TERMINAL BOARD, BARRIER: six 6-32 thd x 1/4" long binding head machine screws.	TM102-6

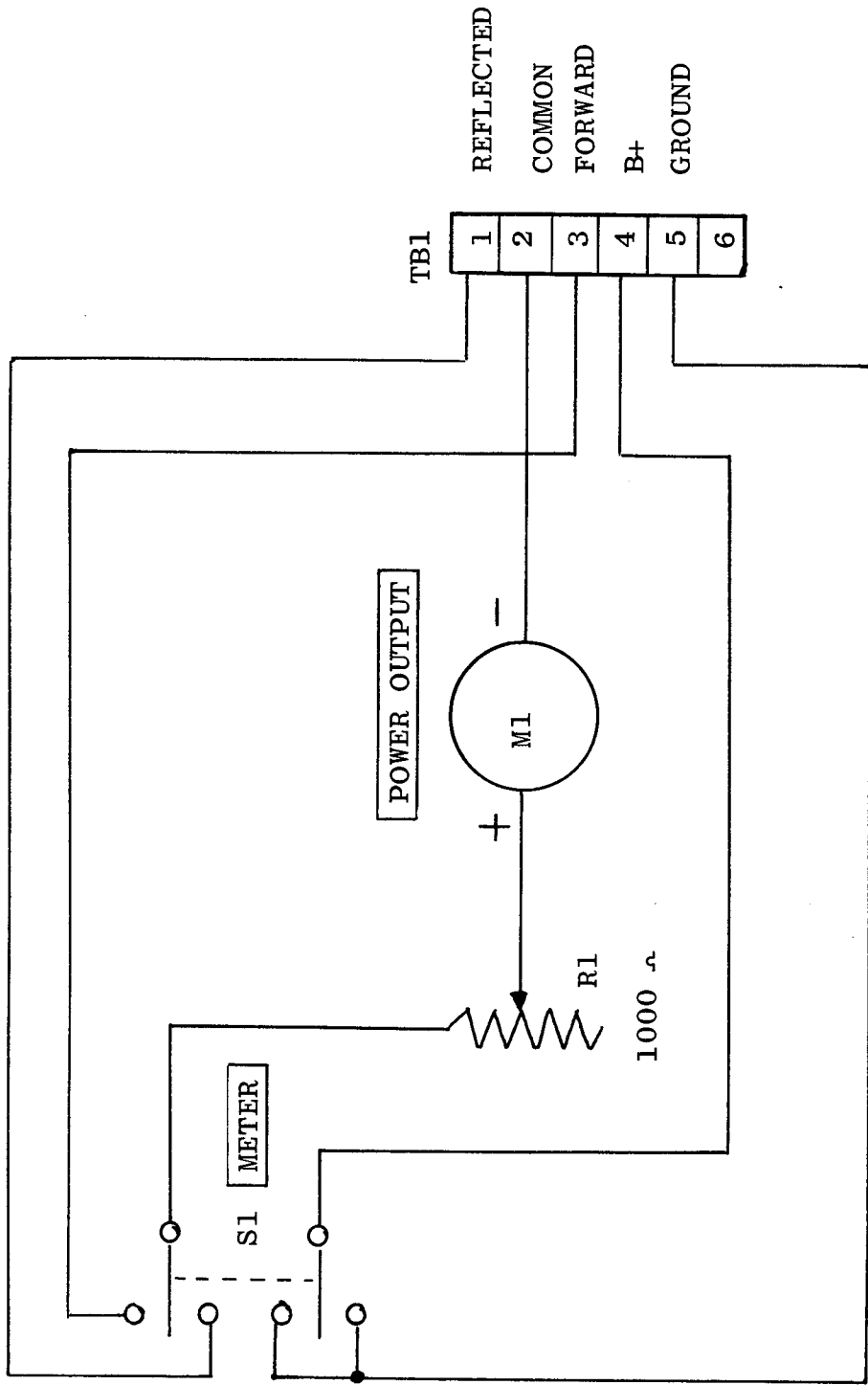

CK1114

Figure 4. Schematic Diagram