

IF IT IS FOUND DESIRABLE TO CHANGE ANY TOLERANCE OR OTHER DETAIL SPECIFIED ON THIS DRAWING NOTIFY THE PURCHASER PROMPTLY.

MAXIMUM ALLOWABLE TOLERANCES HAVE BEEN DETERMINED AND DEVIATIONS WILL BE CAUSE FOR REJECTION. REMOVE ALL BURRS AND SHARP EDGES

SM-108 B

PERSONS RECEIVING THIS DRAWING
 THE TECHNICAL MATERIEL CORPORATION claims copyright in this drawing and its contents. This drawing is issued in confidence for engineering information only and may not be reproduced or used to manufacture anything shown hereon without permission from THE TECHNICAL MATERIEL CORPORATION to the user. This drawing is loaned for mutual assistance and is subject to recall at any time.

Property of:
 THE TECHNICAL MATERIEL CORPORATION
 MAMARONECK, NEW YORK

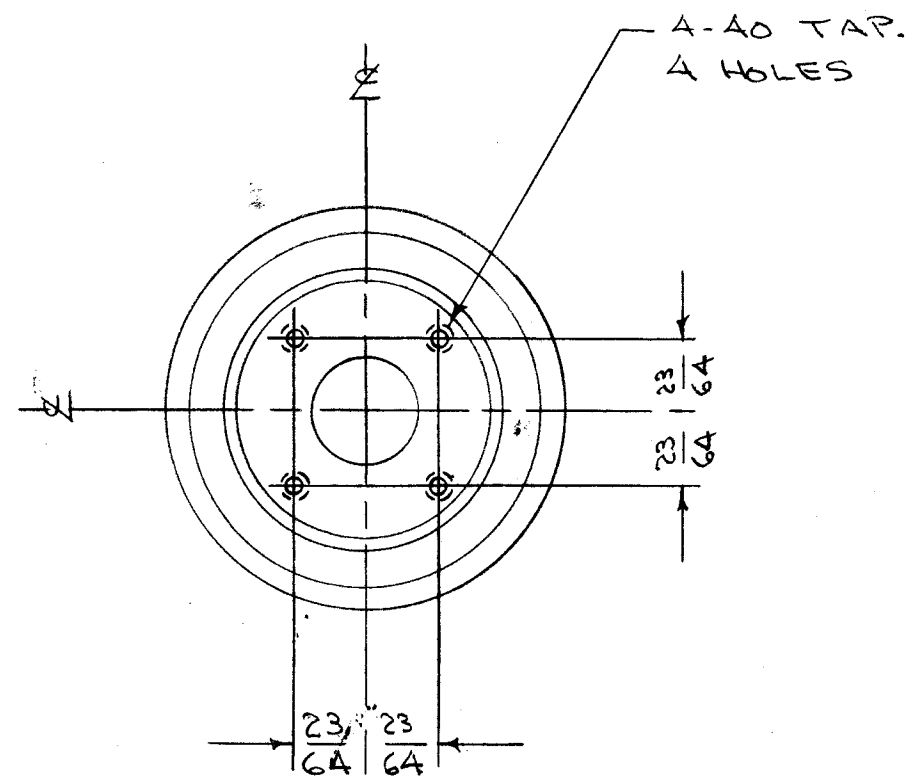
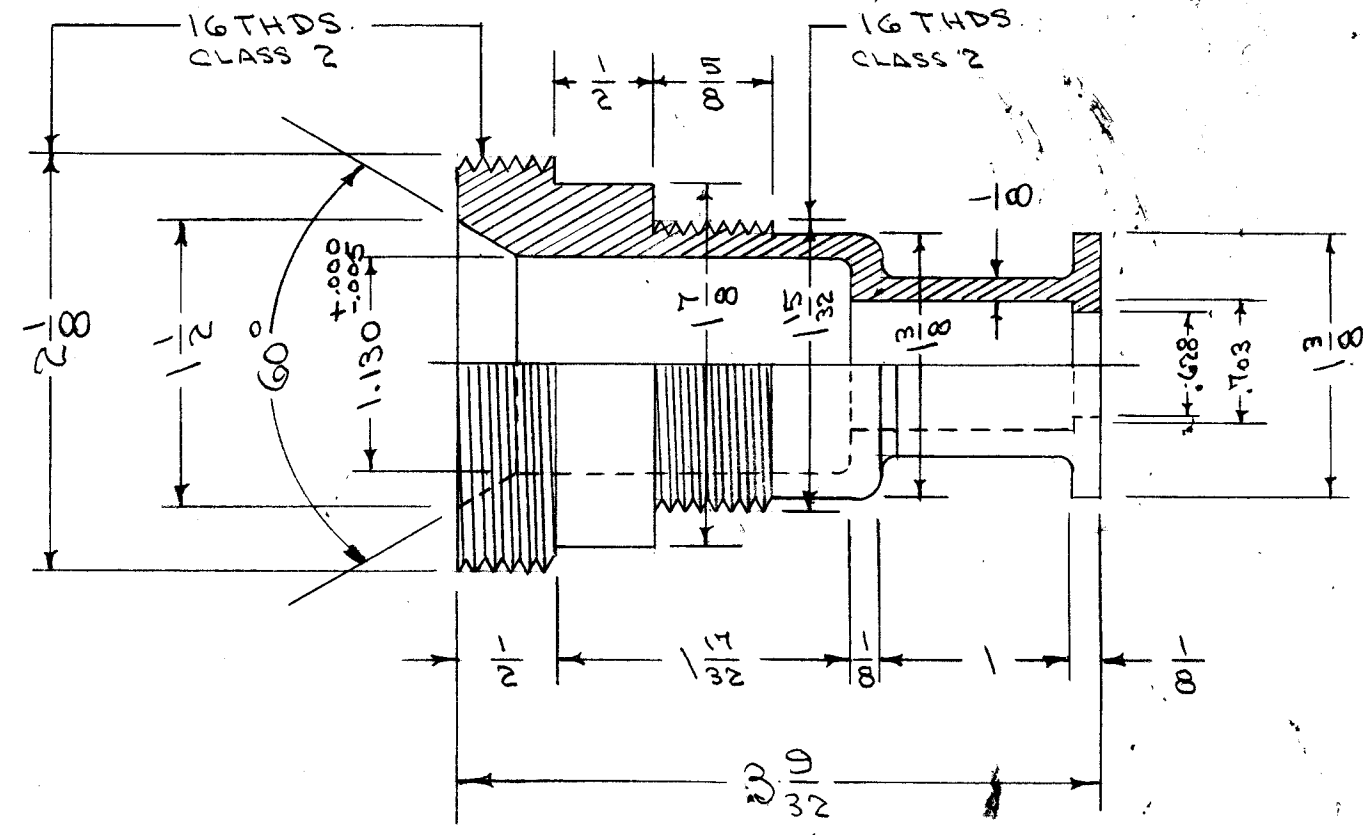

ISSUE	ITEM	CHANGED FROM	DATE	CN. NO.	DRAFTS	CHECKER	ENG. APP.
A	1	Tol. Added To 1.130	7/1/58	1	AKG	15	AKG
-	-	REDRAWN - NO CHANGE	7/2/58	-	AKG	15	AKG

TOLERANCES	SCALE:	TCA-85/12	154	A-133	9-4-52
DEC. DIM. ±.005 FRAC. DIM. ± 1/64 ANGULAR DIM. ± 1°	DRILL, PUNCH, COMMERCIAL STOCK SIZES AND MANUFACTURERS TOLERANCES ARE NOT INCLUDED.	MODEL	PROJECT NO.	ASSY. NO.	DATE
ALL OTHERS		REQ. PER UNIT	USED ON		

REQ. ITEM	PART NO.	DESCRIPTION	SYMBOL
CASTING		THE TECHNICAL MATERIEL CORP., MAMARONECK, NEW YORK	
STOCK SIZE			
BRASS		ADAPTER BODY	
MATERIAL WEIGHT PER PC.			
FREE MACHINING			
TYPE & TEMPER			
HEAT TREAT. SPEC.			
FINISH & SPEC. NO.			
8-105 CAD. PLATE .0002 THK.			
DRAWN		ELEC. DES. APP.	MECH. DES. APP.
CHECKED		FINAL APPROVAL	
		SM-108	B