

DATE 23 January 1964
SHEET 1 OF 11

TMC SPECIFICATION NO. S - 812

A

O. Pose
COMPILED
CHECKED

VP
BP

TITLE:

APPROVED

COMPLETE TEST INSTRUCTIONS
FOR
THE SBG-11A SYSTEM

DATE 23 January 1964
SHEET 2 OF 11

TMC SPECIFICATION NO. S-812

A

O. Pose
COMPILED

NP
CHECKED

TITLE: TESTING OF THE SBG-1LA SYSTEM

APPROVED

I. PRELIMINARY

- A. Connect RF and power cables to units as shown in CK-712.
- B. Inspect rack for mechanical imperfections:
 - 1. Insure that cables are free when separate units are pulled out and tilted from rack.
 - 2. Units should line up in rack together; there should not be any contact between front panel edges.
 - 3. Units should slide freely.
- C. Connect power to rack input J909.
- D. Set CPP-2 and CHG power switches to "ON". CHG and CMO oven lights should be on. Because of the delay tube in the CPP-2, a 60-second wait is necessary before B+ is applied to its associated units. This should be observed.
- E. CBE and CSS power switches should be turned to their "ON" positions.
- F. LFA-4 power and B+ switches should be turned.
- G. SBG system should have at least a 24-hour warm-up period before testing. This will allow ovens to warm up and cycle.

II. TEST EQUIPMENT REQUIRED

- A. One 50 ohm, non-inductive, 20 watt resistance.
- B. One 70 ohm, non-inductive, 4 watt resistance.
- C. One electronic counter, H.P. 524C or equivalent.
- D. One RF VTVM, H.P. 410 or equivalent.
- E. One Spectrum Analyzer, Model LP-1A with modified rack.
- F. One PTE-3.

Test Instructions:

- A. Proceed as outlined in Part 1 of the Test Procedure.
- B. After completion of Part 1, proceed with Part 2.

DATE 23 January 1964

SHEET 3 OF 11

TMC SPECIFICATION NO. S - 812

A

O. Pose
COMPILEDMP
CHECKED

TITLE: TESTING OF THE SBG-11A SYSTEM

APPROVED

FIGURE 1

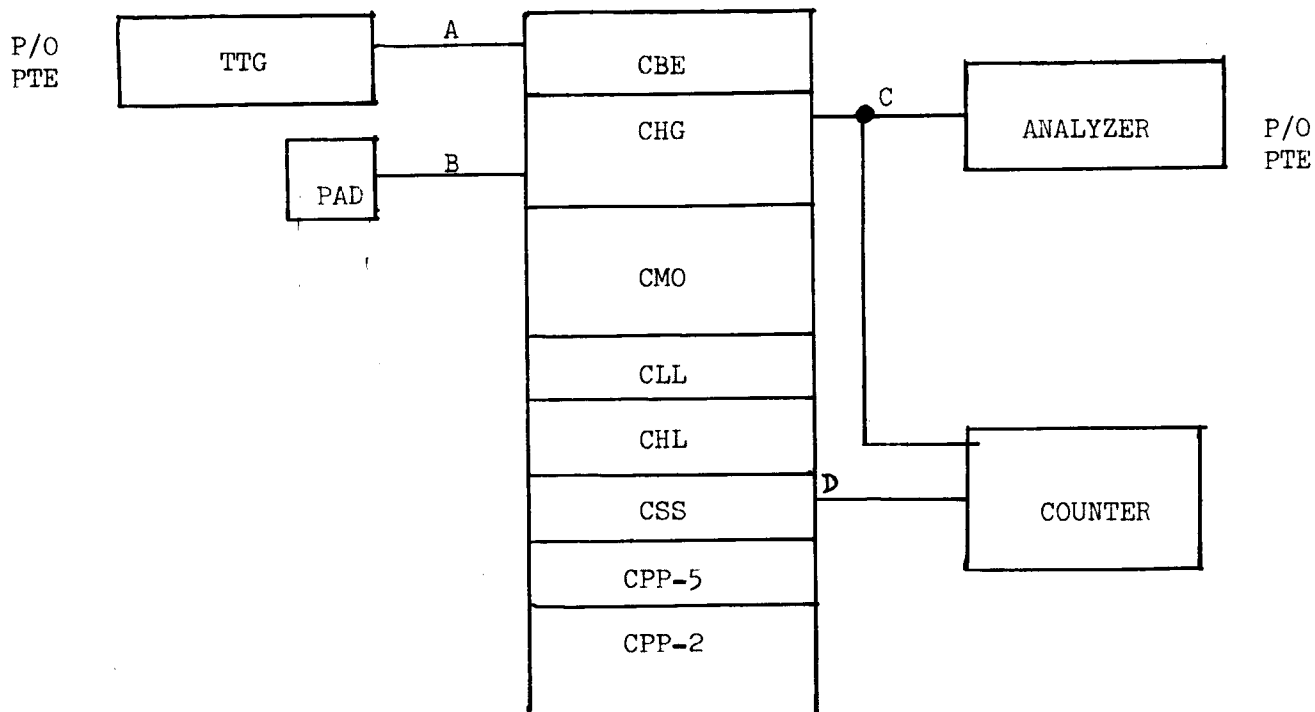
TEST EQUIPMENT SET-UP

NOTE: Two-tone audio from TTG to Channel 1 or Channel 2 of the CBE. A single conductor shielded wire can be used for this purpose. TTG connections are as follows:

Shield of wire to Terminal 2 of E500, audio out strip. Insulated wire should be connected to Terminal 1 of E500. The remaining end of the shielded wire should be connected to the CBE in the following manner. For Channel 1, connect shield of wire to Terminals 1 and 2 of E201. Insulated wire should be connected to Terminal 4. For Channel 2, connect shield of wire to terminals 8 & 9. Insulated wire should be connected to terminal 6.

Either one of the two channels can be used. A check should be made, with the channel that is not going to be used throughout the complete frequency test, with at least one of the test frequencies. This is to insure that the channel is functioning properly, and the channel switch is wired properly.

DATE 23 January, 1964
SHEET 4 OF 11

TMC SPECIFICATION NO. S - 812

A

O. Pose
COMPILED

NP
CHECKED

TITLE: TESTING OF THE SBG-1LA SYSTEM

APPROVED

FIGURE 2

TEST EQUIPMENT SET-UP

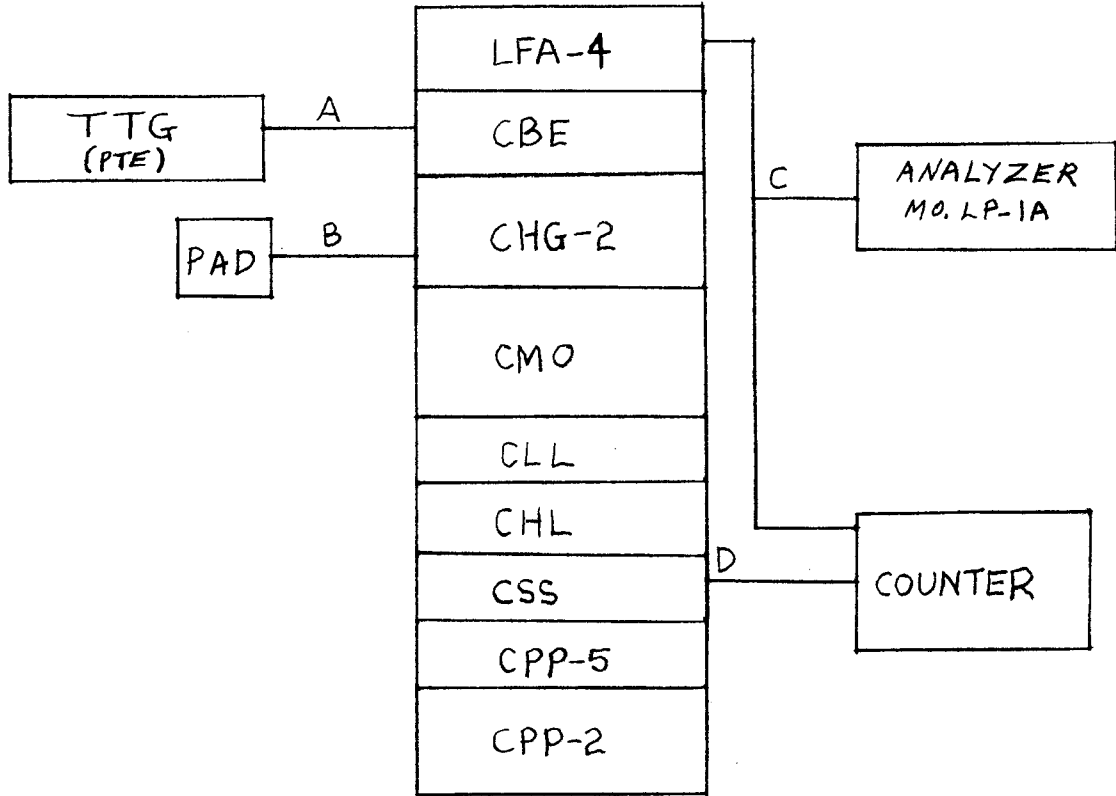

DATE 23 January 1964

SHEET 5 OF 11

TMC SPECIFICATION NO. S - 812

A

O. Post
COMPILED

MP
CHECKED

TITLE: TESTING OF THE SBG-11A SYSTEM

APPROVED

PART 1

- I. A. CHG J2704 output connected to load.
- B. CHG J2705 monitor connected to analyzer and counter signal input connectors.
- C. CSS J602 IMC out to counter frequency standard input; set counter standard switch to external. This is to eliminate any error in the output frequency readout on the counter due to a difference in frequency between the SBG standard (CSS) and the standard in the counter.

II. GENERAL CHECK-OUT

This can only be accomplished by the completion of a 24-hour warm-up.

- A. Observe if ovens are cycling in CMO and CHG (i.e. oven lights should go on and off).
- B. The CMO drive control should be turned approximately mid-range. This is to prevent pinning the CHG MF meter.
- C. A square should appear on the scope in the L-1, L-2, and L-3 positions of the CLL. This should be true for all the positions on the KCS and 100 CPS switches.
- D. The CHG sync indicator light should remain on in each of the band switch positions.
- E. Connect test equipment as shown in Figure 1.
- F. Set CMO counter dial to 1750 KCS, function switch in calibrate position. Beat should be observed on calibrate indicator light. If not, alignment of the oscillator ends is necessary.

1. Oscillator Alignment:

- a. Set CMO counter 1750 KCS. 1750 KCS should be approached from the lower frequency side (i.e. 1650 KCS to 1750 KCS). This will prevent any error due to backlash.
- b. Rotate calibrate knob until beat on calibrate indicator light is observed. As an additional check, the output of the CMO through a 20 db pad, can be read on the counter.
- c. Set CMO counter to 3750 KCS. Again, as in the 1750 KCS case, 3750 KCS should be approached from the lower frequency side (i.e. 3650 KCS to 3750 KCS).

DATE 23 January 1964
SHEET 6 OF 11

TMC SPECIFICATION NO. S - 812

A

O. Pose
COMPILED

MP
CHECKED

TITLE: TIESTING OF THE SBG-11A SYSTEM

APPROVED

d. Rotate MO "High End" trimmer until beat on calibrate indicator light is observed. This trimmer is located behind the front panel hole adjacent to the calibrate knob.

e. Repeat Step "a" through "d" until beat is observed at 1750 KCS and 3750 KCS without further adjustments. This completes the oscillator alignment.

G. Output of the TTG should be adjusted to .015 volts at the terminals of the CBE.

H. Set CBE channel switches to 1 or 2, depending on terminal connections. Carrier control to "OFF" position; TTG set for two tones audio.

III. SBG TUNING

A. Determining Output Frequency

The output frequency is determined by adding the bandswitch numeral which is in MCS, to the CMO output frequency. Take for example, that a frequency of 12,751,200 cycles is desired. Bandswitch is set to 11,750-13,750, number 10 position.

$10,000,000 \text{ cycles} + 2,751,200 \text{ cycles} = 12,751,200 \text{ cycles.}$

B. CMO and CLL Adjustment

1. Turn CMO function switch to operate and MO counter to 2750 KCS.

2. Vary Tuning KCS control for maximum reading on output tune meter. This will occur at approximately 2.75 on the panel dial.

3. The KCS switch is set to one (1), and the 100 CPS switch two (2). This is because the synthesizer only controls the 100 cps and 1000 cps digits of the MO. We depend on the MO accuracy for the thousand, hundred, and ten digits on the MO counter. Note the color coding and CLL and CMO panels.

4. Synchronizing of CMO at 2750 KCS -

a. Vary the MO control approximately 2 KC above and below 2750 KCS. The sync meter will follow in the same direction as this control is varied (i.e. when the MO control is varied to the right the sync meter pointer will move to the right).

b. Vary the MO control 1 KC above and below 2750 KCS (i.e. 2749-2751 KCS). The sync indicator light should remain on. The sync meter should follow the variation of the MO control through the green range of the sync meter face. This is regarded as the lock-in range.

DATE 23 January 1964

SHEET 7 OF 11

TMC SPECIFICATION NO. S-812

A

O. Pose
COMPILED

WP
CHECKED

TITLE: TESTING OF THE SBG-11A SYSTEM

APPROVED

c. As a final check on sync action, vary the MO control slowly approximately 3 KCS above and below 2750 KCS. As the loop drops out of sync, the sync indicator light will go off (sync meter will fall to center scale position).

C. CHG Adjustment

1. Bandswitch is set to the output frequency desired. In the case of the example, it is set at 11,750-13,750, (Bandswitch No. ten [10]).

2. Vary the MF tuning control for maximum indication on the CHG MF tuning meter. Care should be taken as in Part III "B". This will occur at approximately 2.75 on the panel dial in the example. MF tuning meter must never be operated in the red region.

3. Turn B+ switch on "ON" position.

4. Peak output meter at 1750 KCS with the main tuning control.

5. Rotate output control to an output meter reading of approximately 8 or 9.

6. The counter will read the output frequency \pm one count. In the case of the example, it will read 12,751,200 cycles.

7. Set up frequencies 25,200,400 cycles and 30,800,900 cycles. Note the readout on the counter. It can be seen in the Test Equipment Set-up, Figure 1, that the CSS is also used as the standard for the counter. Therefore, any error in the counter read-out is due to the CSS IMC STANDARD.

8. With the output control fully clockwise, the output voltage across the 70 ohm load should be 8.5 volts or better.

IV. DISTORTION TEST

A. Panalyzer adjustment for measuring distortion:

1. Gain - full clockwise position.
2. Amplitude scale switch - LOG.
3. Cal. OSC level - OFF
4. Input Attenuators - OFF.
5. I.F. Attenuation - 20 db.
6. Sweep width selector - 7 KC.
7. AFC - OFF.

DATE 23 January 1964
SHEET 8 OF 11

TMC SPECIFICATION NO. S-812

A

O. Pose
COMPILED

NP
CHECKED

TITLE: TESTING OF THE SBG-11A SYSTEM

APPROVED

8. The VOX should be set at 500 KC above the frequency being measured. In the case of the example, 12,751,200 cycles, the VOX frequency should be set at approximately 13,251,200 cycles.

B. Distortion measurements should be taken at the frequencies indicated on Chart 1. In each case, the distortion products must be at least 40 db down on the two tone test.

V . SPURIOUS

A. Set CBE channels to "OFF". Carrier should be inserted to maximum of zero (0) position.

B. Analyzer sweep should be set on 7 KC.

C. Spurious measurements should be taken at 3 MCS output of CHG. Spurious should be down 60 db or better.

D. It is important that the spurious check should be made through the complete lock-in range of the CMO.

VI . CARRIER SUPPRESSION

A. Set analyzer IF attenuator to the 20 db position.

B. With the carrier adjusted as above, set the carrier representation on the analyzer screen to the zero (0) db line.

C. Switch IF attenuator to zero (0) db position.

D. Rotate carrier control to "OFF" position.

E. Carrier should be down 55 db or better.

VII . SIDEBAND CHECK

A. Set carrier to "OFF" position.

B. TTG AUDIO TONE SELECTOR set to TONE 1 position.

C. Set CBE USB switch to Channel 1 or 2 depending on terminal connections to E201, LSB Switch to "OFF".

D. Read frequency on counter.

E. Set CBE LSB switch to Channel 1 or 2 depending on terminal connections to E201, USB switch to "OFF".

DATE 23 January 1964
SHEET 9 OF 11

TMC SPECIFICATION NO. S-812

A

O. Pose
COMPILED

MP
CHECKED

TITLE: TESTING OF THE SBG-1LA SYSTEM

APPROVED

F. Read frequency on counter. This frequency should be 1870 CPS lower than first reading if a 935 CPS tone is used from the TTG. If this second reading is not lower in frequency, check for proper filter placement in the CBE or cable connections.

PART 2

- I. A. LFA J3004 output connected to load.
- B. LFA J3005 monitor connected to analyzer and counter.
- C. Connect test equipment as shown in Figure 2.

II. DETERMINING OUTPUT FREQUENCY

- A. The output frequency is determined by KCS above 2 MCS on the CMO.

Example: If 300 KCS output is required, set CMO and CHG for 2.300.000 MCS.

NOTE: The output control on the CHG must be set to 4 or 5 divisions on the CHG output meter.

III. SBG-1LA OUTPUT

- A. Set up the system for 300 KCS, using *two tones*.
- B. Advance LFA output control for 5 watts PEP on HP410 meter connected to the output load.
- C. Note the reading on LFA output meter and enter the number into Report Sheet.

IV. DISTORTION TEST

- A. Measure distortion of SBG-1 system only and enter the results on the report sheet part 1.
- B. Using two tones, measure distortion of SBG-1LA and enter results into Report Sheet, part 2.
- C. Remove *audio tones* and reinsert carrier for full 5W output and enter results on report sheet, part 3.

NOTE: This system is now ready for shipment.

DATE 23 January 1954

SHEET 10 OF 11

TMC SPECIFICATION NO. S - 812

A

O. Pose
COMPILED

NP
CHECKED

TITLE: TESTING OF THE SBG-11A SYSTEM

APPROVED

THE TECHNICAL MATERIEL CORPORATION
MAMARONECK, N.Y.

SBG-11A TEST DATA SHEET - Page 1 of 2

MFG. NO.: _____

A. Mechanical

1. Slides _____ OK
2. Front panel line-up _____ OK
3. Cables _____ OK

B. Oven Cycling

1. CMO _____ OK
2. CHG _____ OK

C. CMO

1. Calibration _____ OK
2. Geat Indicator _____ OK

D. CHG

1. Output Voltage _____ Volts

E. Carrier Suppression _____ db

A

O. Pose
 COMPILED

EXP
 CHECKED

TITLE: TESTING OF THE SBG-11A SYSTEM

APPROVED

Lower Band Limit	Upper Band Limit	Band Sw Number	Output Tuning Dial Band	Counter	Spurious Distortion
1.750	2.750	0	A		
3.750	4.750	2	B		
	4.000	2	B		
	5.000	2	B		
5.750	6.750	4	C		
7.750	8.750	6	C		
9.750	10.750	8	C		
11.750	12.750	10	C		
13.750	13.750	12	D		
15.750	15.750	14	D		
17.750	17.750	16	D		
19.750	19.750	18	D		
21.750	21.750	20	D		
23.750	23.750	22	D		
25.750	25.750	24	D		
27.750	27.750	26	D		
29.750	28.750	28	D		
31.750	30.750	28	D		
	32.750	30	D		
	33.750				

*S/D:40db down from each tone

Freq. CMO Freq. Band Sw Number Output Tuning Dial Band

50KCS 2.050MCS 0 A
 300KCS 2.300MCS 0 A
 500KCS 2.500MCS 0 A
 *S/D:39db down from each tone(equiv.45db PEP)

"POWER OUTPUT:5 WATTS AVE."

Serial Number _____
 Date _____
 Tested by _____
 Accepted by _____

TEST REPORT SHEET PAGE 2 of 2

*SIGNAL TO DISTORTION

