

TMC SPECIFICATION

NO. S 1157

REV: 0 A

COMPILED: J. Sabatino
CHECKED: JRL 12-1-66
APPD: [Signature] 12/1/66
SHEET 1 OF 8

TITLE:

SPECIFICATIONS

for

KIT-274

and

KIT-274-50

NOTE ALL ITEMS WITHOUT ASTERISK (*) SHALL BE SUPPLIED FOR KIT-274 AND
KIT-274-50. ALL ITEMS REFERENCED WITH ASTERISK (*) SHALL BE
SUPPLIED FOR KIT-274-50 ALSO.

TMC SPECIFICATION

NO. S 1157

REV: A

COMPILED:

CHECKED:

APPD:

SHEET 2 OF 8

TITLE: KIT-274, KIT-274-50

I. EQUIPMENT AFFECTED

A. All GPT-10K Transmitters which are required to accept 480, 450, 430, 410, 380V input.

*B. All GPT-10K Transmitters which are required to operate on 50 cycle operation.

II. PURPOSE

A. To install TF345 input transformer, mounting rails and protective covers.

*B. To replace interval timer, time total meter, centrifugal fan and electrical solenoid required for 50 cycle operation.

III. MATERIALS SUPPLIED

<u>ITEM NUMBER</u>	<u>TMC PART NUMBER</u>	<u>QTY</u>	<u>DESCRIPTION</u>	<u>SYMBOL</u>
1	TF345	1	XFMR,PWR,SD	T801
2	MS6038	2	CHANNEL, XFMR MTG	
3	SCHH2520BN28	4	BOLT, MACH	
4	LWS25MRN	8	WASH., LK, SPLIT	
5	SCHH2520BN12	4	BOLT, MACH	
6	LWE10MRN	2	WASH., LK, EXT	
7	FW10HBN	2	WASH., FLAT	
8	SCBP1032BN8	2	SCR, MACH	
9	FW25HBN	4	WASH., FLAT	
10	PX1002	2	BLOCK, MTG	
11	LD2181/PX973-1	1	COV, PROTECT, XFMR	
12	NP362-46	1	PLATE-IDENT-MOD	

TMC SPECIFICATION

NO. S 1157

REV: A

COMPILED:

CHECKED:

APPD:

SHEET 3 OF 8

TITLE: SPECIFICATIONS for KIT-274 and KIT-274-50

III. MATERIALS SUPPLIED (cont)

<u>ITEM NUMBER</u>	<u>TMC PART NUMBER</u>	<u>QTY</u>	<u>DESCRIPTION</u>	<u>SYMBOL</u>
13	DRILL, 1/8	1	DRILL, TWIST, 1/8 DIA	
14	DRILL, #7 (.2010)	1	DRILL, TWIST, NO. 7	
15	TAP, #1/4-20 NC-2 THD	1	TAP, THD CTG	
*16	TI101-5-50	1	TIMER, INTERVAL	M701
*17	MR125-2-50	2	METER, TIME TOTAL	M700, M702
*18	BL111-50	1	FAN, CENTRIFUGAL	B800
*19	SZ100-50	1	SOLENOID, ELECTRICAL	L802

IV. TOOLS REQUIRED

A. To be supplied by installing activity.

V. PROCEDURE

CAUTION.....CAUTION.....CAUTION

Remove AC input to transmitter main frame and auxiliary frame before proceeding with modification. Ground out all high voltage circuitry with shorting stick.

A. PREPARATION FOR MODIFICATION

1. Open rear door to main frame.
2. Looking in left rear of main frame, locate ac input box.

B. REMOVAL OF AC INPUT ASSY AND INSTALLATION OF XFMR

1. Remove leads from insulators E8008, 8009, and 8010. Do not remove other end of leads.
2. Remove AC input box and covers (no longer required).

TMC SPECIFICATION

NO. S 1157

REV: A

COMPILED:

CHECKED:

APPD:

SHEET

6

OF 8

TITLE: SPECIFICATIONS for KIT-274 and KIT-274-50

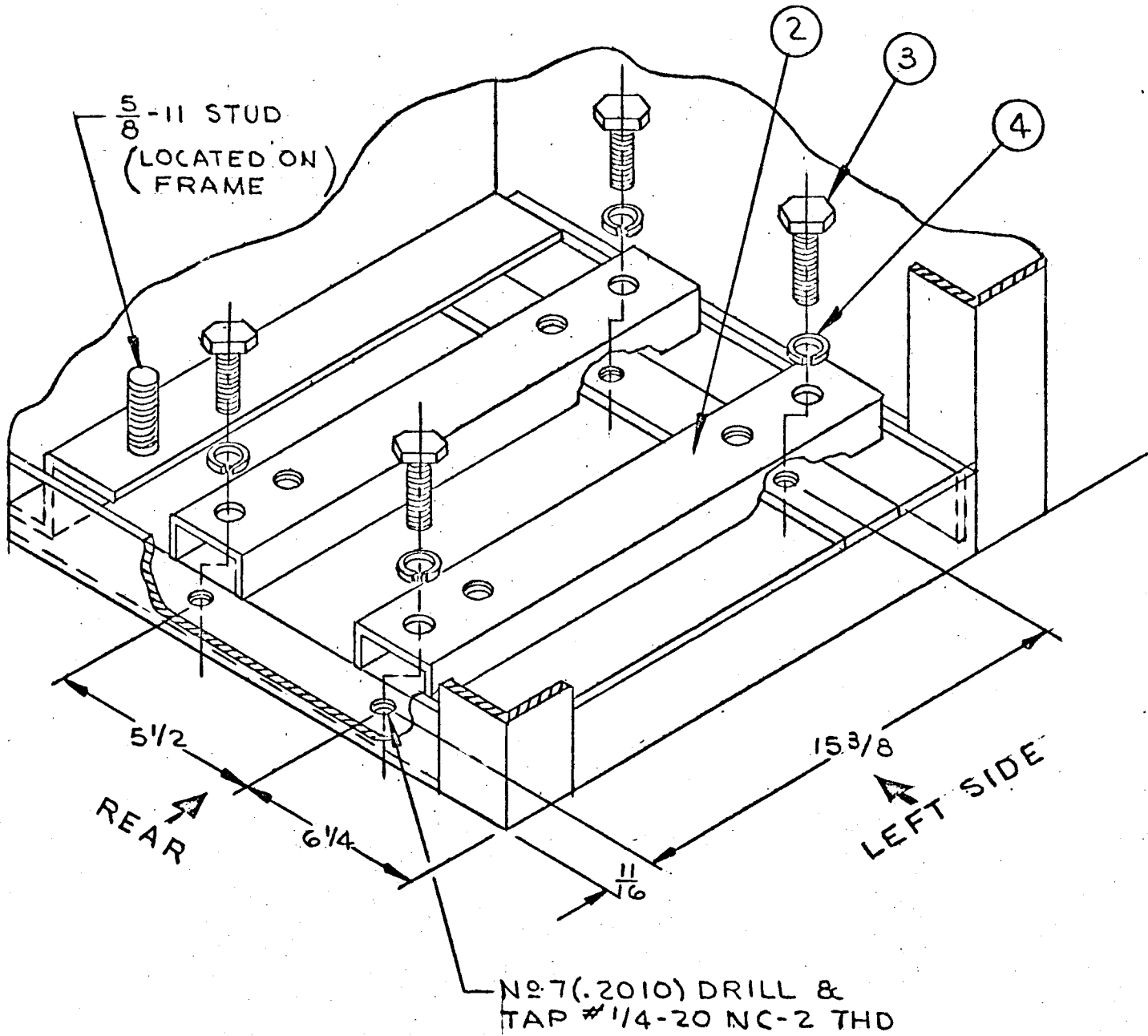

FIG. 1
LEFT REAR VIEW
OF MAIN FRAME

TMC SPECIFICATION

NO. S 1157

REV: *A*

COMPILED:

CHECKED:

APPD:

SHEET 8 OF 8

TITLE:

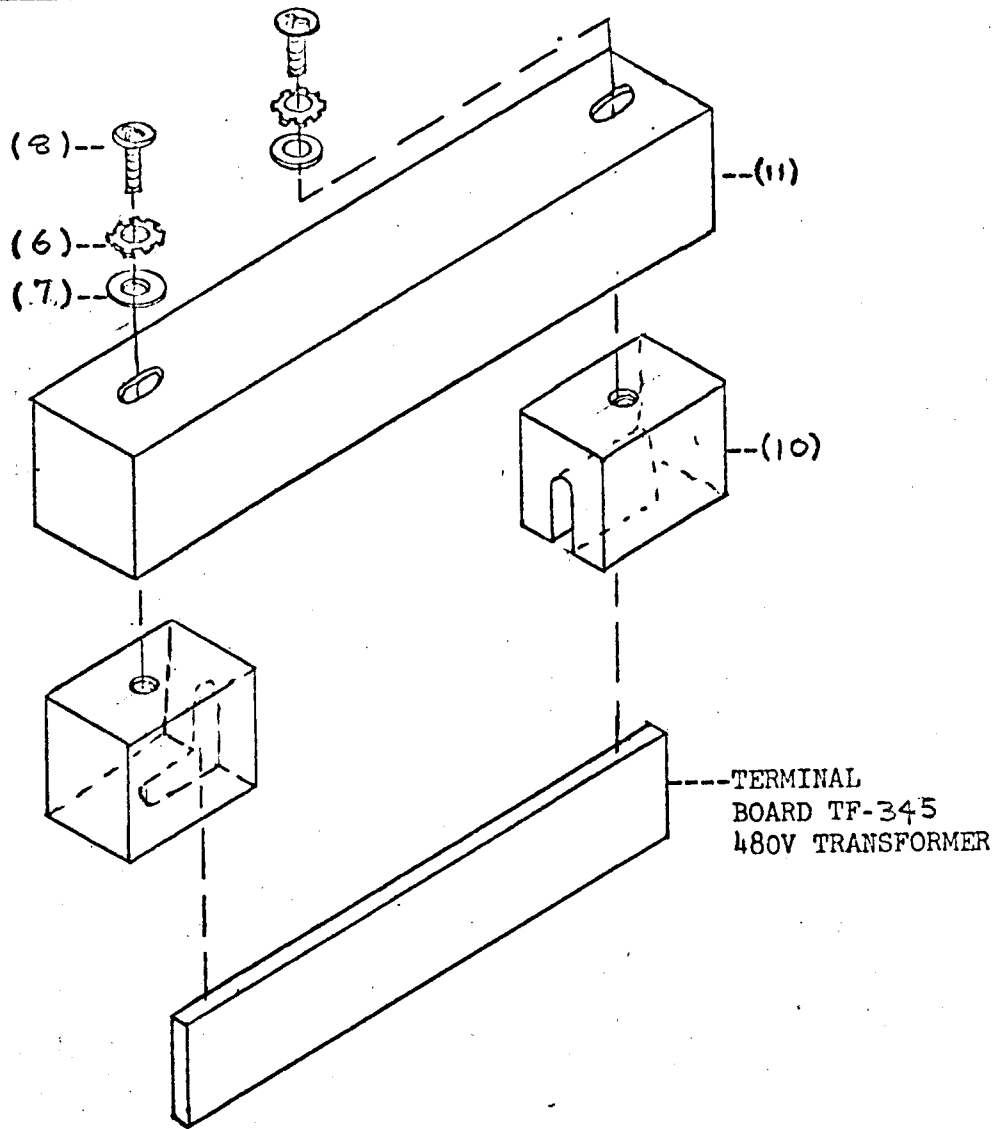

FIGURE IV

PROTECTIVE COVER MOUNTING

