

REQ. PER UNIT	USED ON		
	MODEL	ASS'Y. NO.	DATE
	GPT-200K		9-11-63
	TTR-10		9-11-63

RY-140 A

TMC PART NO.	MFRS. PART NO.	DIMENSIONS					MATL.	DUROMETER	COLOR
		A	B	C	D	E			
RY-140-1	ZX-4065	1/16	1/8	1/32	3/16	1/4	NEOPRENE	50-60	BLACK
RY-140-2	ZX-4088	1/4	3/8	1/16	7/32	9/32	NEOPRENE	50-60	BLACK

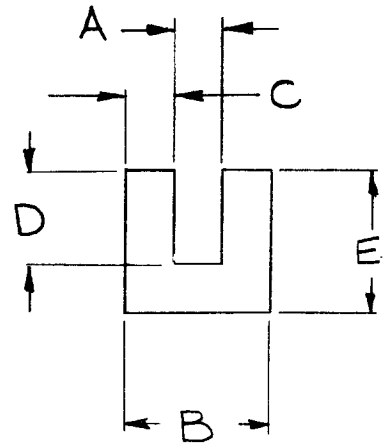

NOTE:
TMC PART NO. TO BE IN THE FOLLOWING FORM.

RY-140 - 1 - 10.00
 BASIC NO. LENGTH IN
 PER CHART INCHES

							REQ. ITEM	PART NO.	KOHN DESCRIPTION E3037	SYMBOL	
							STOCK SIZE		THE TECHNICAL MATERIEL CORP. MAMARONECK. NEW YORK		
									RUBBER CHANNEL, U TYPE		
A	RY-140-2 ADD. TO CHART	2-18-65	13597	82.	QCB		MATERIAL				
SYM	DESCRIPTION	DATE	CH. NO.	DRAFTS	CHECKER	ENG. APP.					
UNLESS OTHERWISE SPECIFIED DIMENSIONS ARE IN INCHES AND INCLUDE CHEMICALLY APPLIED OR PLATED FINISHES		SCALE							<i>Arkins 9/11/63</i> <i>HO 9/11/63</i> <i>BP</i> DRAWN CHECKED FINAL APPROVAL		
DECIMALS .X ± .05 .XX ± .01 .XXX ± .005		FRACTIONS ± 1/64 ANGLES ± 0° 30'		TOLERANCES		CODE	S401-231		TYPE & TEMPER HEAT TREAT. SPEC. R KOHN R KOHN		
							FINISH & SPEC. NO.		ELEC. DES. APP. MECH. DES. APP. RY-140 A		