

REQ. PER UNIT	USED ON			PX865 Ø
	MODEL	ASS'Y. NO.	DATE	
1	LFRA-1	A3988	11-11-64	

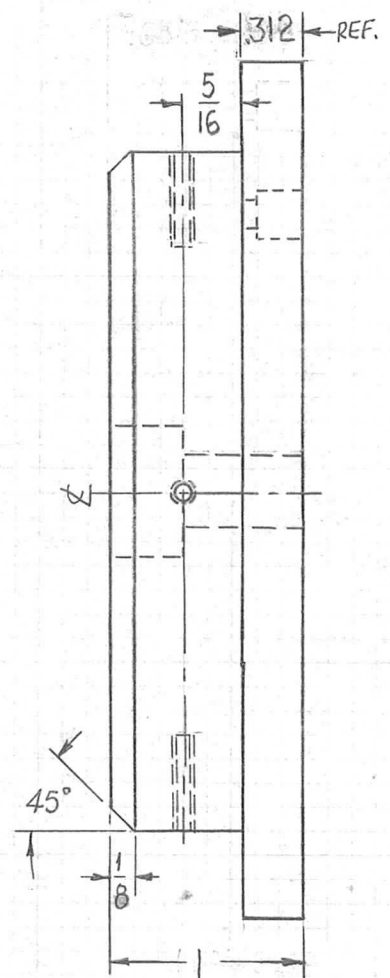

HOLE	DESCRIPTION	REQ.
A	DRILL & TAP FOR 6-32 X 1/2 DP.	4
B	SEE DETAIL	1
C	SEE DETAIL	1

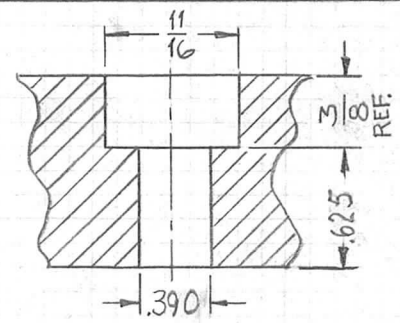
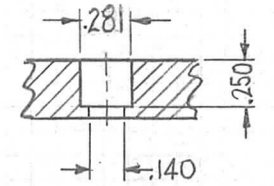

REQ.	ITEM	PART NO.	DESCRIPTION	SYMBOL
Ø	ORIGINAL RELEASE FOR PRODUCTION	11-25-64	Ø 2.L.	
X	EXP. RELEASE	11-11-64	X SRG	
UNLESS OTHERWISE SPECIFIED DIMENSIONS ARE IN INCHES AND INCLUDE CHEMICALLY APPLIED OR PLATED FINISHES		SCALE		
		1:1		
DECIMALS .X ± .05 .XX ± .01 .XXX ± .005		FRACTIONS ± 1/64 ANGLES ± 0° 30'	CODE A	
TOLERANCES				
REQ. ITEM		PART NO.	DESCRIPTION	SYMBOL
		1"	Ø POSE	
XXX PHENOLIC BLACK			THE TECHNICAL MATERIEL CORP. MAMARONECK, NEW YORK	
MATERIAL			PLATE, ROTATING	
TYPE & TEMPER		HEAT TREAT. SPEC.	DRAWN	CHECKED
			SRG	@ 11-17-64 RDE
FINISH & SPEC. NO.		ELEC. DES. APP.	MECH. DES. APP.	FINAL APPROVAL
				PX865 Ø