

PX-632 A

NOTICE TO PERSONS RECEIVING THIS DRAWING

THE TECHNICAL MATERIEL CORPORATION claims proprietary right in the material disclosed hereon. This drawing is issued in confidence for engineering information only and may not be reproduced or used to manufacture anything shown hereon without permission from THE TECHNICAL MATERIEL CORPORATION to the user. This drawing is loaned for mutual assistance and is subject to recall at any time.

Property of:  
THE TECHNICAL MATERIEL CORPORATION  
MAMARONECK, NEW YORK

HOLES	REQ.
A ~ 17/64 Dia.	1
B ~ 5/16 "	12
C ~ 9/16 "	2
D ~ .203 DIA	2

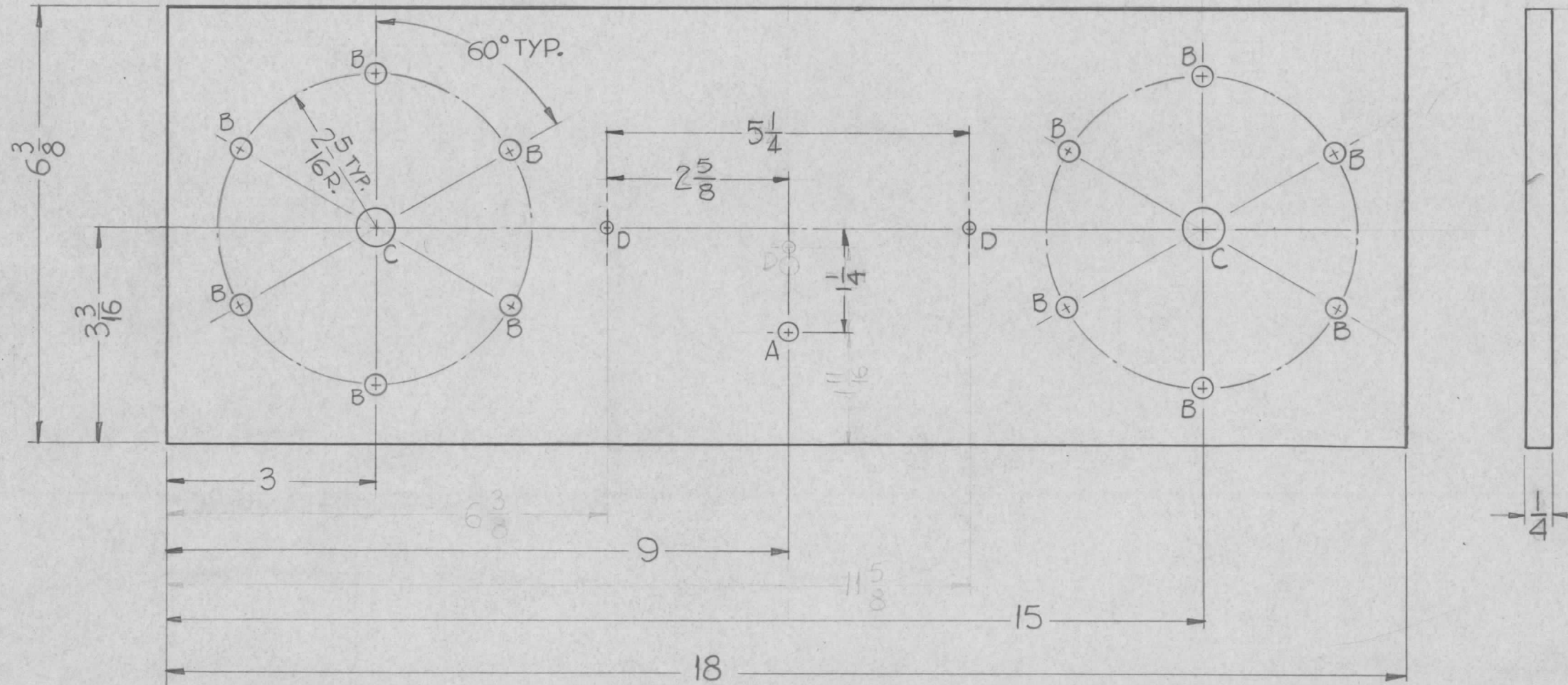

SYM	DESCRIPTION	DATE	CH. NO.	DRAFTS	CHECKER	ENG. APP.
A	① D HOLE DELETED, 2(D) HOLES REDIMENSIONED DIM 6-3/8, 11-5/8 DELETED	12-11-61	6028	RT	<i>[Signature]</i>	<i>[Signature]</i>

UNLESS OTHERWISE SPECIFIED:  
DIMENSIONS ARE IN INCHES  
TOLERANCES ON  
FRACTIONS ± 1/64 DECIMALS ± .005 ANGLES ± 1/2°

SCALE: HALF  
MAXIMUM ALLOWABLE TOLERANCES HAVE BEEN DETERMINED AND ANY DEVIATIONS WILL BE CAUSE FOR REJECTION.  
REMOVE ALL BURRS AND SHARP EDGES

REQ. PER UNIT	MODEL	SECTION	ASS'Y. NO.	DATE
1	TRC-20K			10-25-61

USED ON

REQ. ITEM	PART NO.	DESCRIPTION	SYMBOL
	1/4	THE TECHNICAL MATERIEL CORP. MAMARONECK, NEW YORK	
	STOCK SIZE		
	SILICON GLASS	PLATE, REINFORCEMENT	
	MATERIAL		
	G.7	<i>D.J. Mamm</i> RUZZO	<i>[Signature]</i>
	TYPE & TEMPER	HEAT TREAT. SPEC.	DRAWN CHECKER FINAL APPROVAL
			<i>LB</i> <i>[Signature]</i> PX-632 A
	FINISH & SPEC. NO.	ELEC. DES. APP. MECH. DES. APP.	