

IF IT IS FOUND DESIRABLE TO CHANGE ANY TOLERANCE OR OTHER DETAIL SPECIFIED ON THIS DRAWING NOTIFY THE PURCHASER PROMPTLY.

PX-222 C

MAXIMUM ALLOWABLE TOLERANCES HAVE BEEN DETERMINED AND DEVIATIONS WILL BE CAUSE FOR REJECTION. REMOVE ALL BURRS AND SHARP EDGES

REQ. PER UNIT	USED ON			
	MODEL	PROJECT NO.	ASS'Y. NO.	DATE
3	TAC-1	132	A-720 A-722	1-14-54

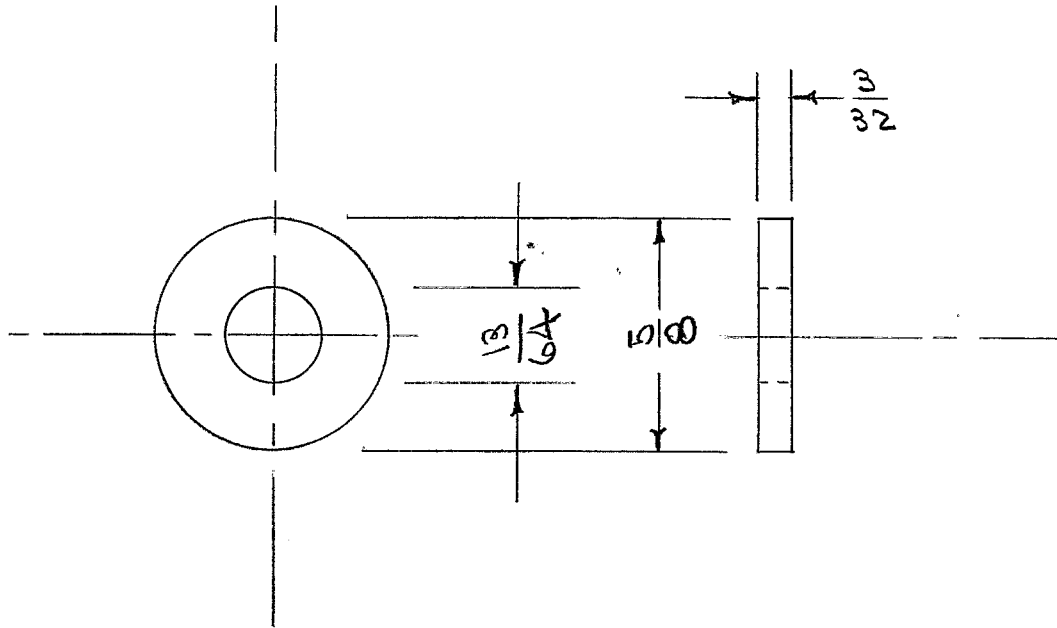

REQ.	ITEM	PART NO.	DESCRIPTION	SYMBOL
		5/8 D. ROD.	THE TECHNICAL MATERIEL CORP. MAMARONECK, NEW YORK	
		STOCK SIZE		
		TEFLON	WASHER, TEFLON	
		MATERIAL	TAC-1	
		WEIGHT PER PC.		
		TYPE & TEMPER		
		HEAT TREAT. SPEC.		
		FINISH & SPEC. NO.		

ISSUE	ITEM	CHANGED FROM	DATE	CN. NO.	DRAFTS	CHECKER	ENG. APP.
C	3	5/8 WAS 1/2	8/4/54	3	EDD	FADE	WDE
	2	13/64 WAS 1/4					
	1	3/32 ±.003					
B	1	WAS G PER UNIT	7/23/54	2	EDD	FADE	WDE
A	1	±.005 WAS ±.002	5-12-54	1	EDD	FADE	WDE

TOLERANCES		SCALE
ALL OTHERS	DEC. DIM. ± FRAC. DIM. ± ANGULAR DIM. ±	DRILL, PUNCH, COMMERCIAL STOCK SIZES AND MANUFACTURERS TOLERANCES ARE NOT INCLUDED.

DRAWN		ELEC. DES. APP.	MECH. DES. APP.
FADE			WDE
CHECKED		FINAL APPROVAL	
		WDE	

PX-222	C
--------	---