

REQ. PER UNIT	USED ON			MS5086	Ø
	MODEL	ASS'Y. NO.	DATE		
1	SWCB-3K		9-10-66		

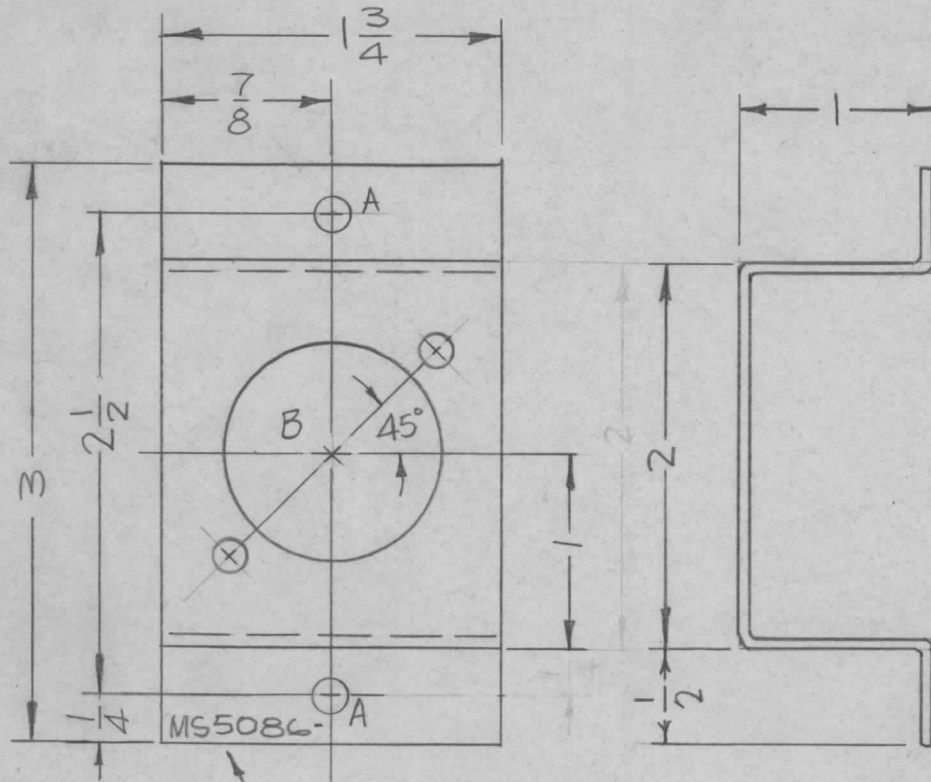

MARK TMC P/N
1/8 HIGH GOTHIC
W/LATEST REV.
LETTER.

HOLES:

A- 11/64 DIA (2 REQ.)

B- SEE DETAIL (1 REQ.)

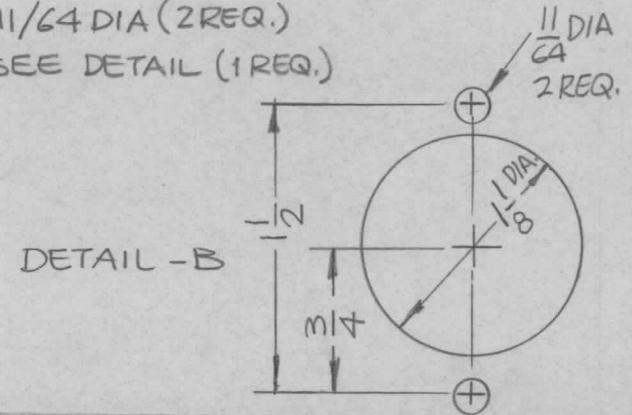

UNLESS OTHERWISE SPECIFIED:

1. USE MATERIAL THICKNESS FOR MAXIMUM RADIUS ON ALL BENDS
2. ALL ANGULAR BENDS 90 DEGREES
3. REMOVE ALL BURRS AND SHARP EDGES

FOR REF. ONLY SEE LD2142

REQ. ITEM	PART NO.	F. BUDETTI	DESCRIPTION	SYMBOL									
Ø	ORIGINAL RELEASE FOR PRODUCTION	2/23/67	Ø CV										
X	EXP. RELEASE	9-10-66	X <i>MS</i> <i>aa</i>										
SYM	DESCRIPTION	DATE	CH. NO.	DRAFTS	CHECKER	ENG. APP.	MATERIAL						
UNLESS OTHERWISE SPECIFIED DIMENSIONS ARE IN INCHES AND INCLUDE CHEMICALLY APPLIED OR PLATED FINISHES							SCALE	5052-H32	<i>MS</i>	<i>JCB</i>	<i>MS</i>		
DECIMALS .X ± .05 .XX ± .01 .XXX ± .005							TOLERANCES	FRACTIONS ± 1/64 ANGLES ± 0° 30'	TYPE & TEMPER	HEAT TREAT. SPEC.	DRAWN	CHECKED	FINAL APPROVAL
TMC FORM 108-A							CODE A	S404 YEL IRIDITE			<i>RT</i>	MS5086	Ø
								FINISH & SPEC. NO.	ELEC. DES. APP.	MECH. DES. APP.			