

REQ. PER UNIT	USED ON			MS5058	Q
	MODEL	ASS'Y. NO.	DATE		
1	KIT300		8-18-66		

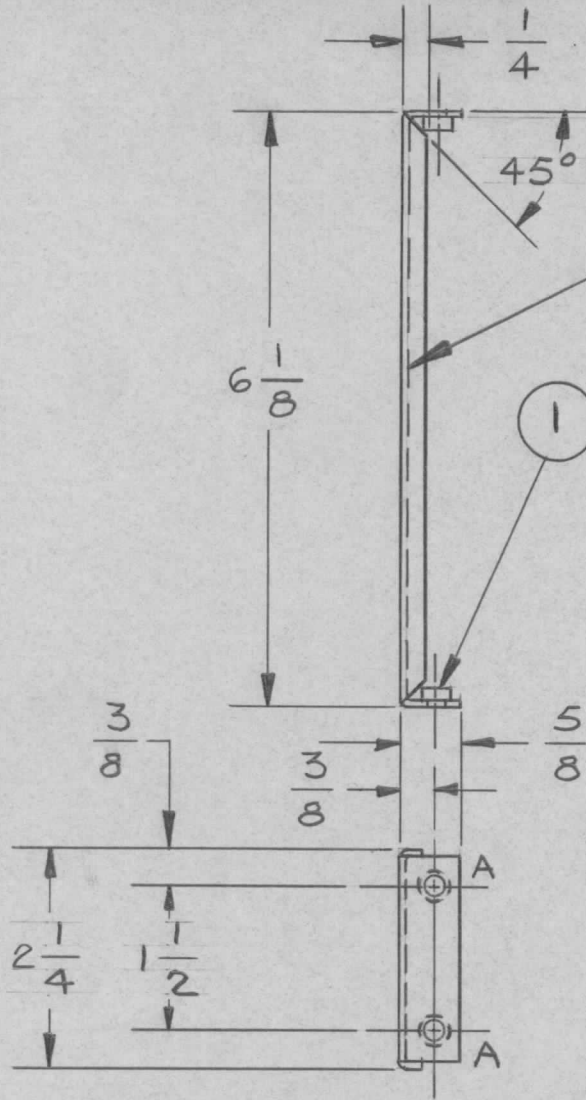

MARK TMC P/N 1/8 HIGH GOTHIC W/LATEST REV LETTER

1 MOUNTED IN ALL "A" HOLES AS SHOWN. AFTER FINISHING

SYM	DES	REQ'D
A	.191-.194	4

4	1	NT129-632-3	NUT, ROUND, SWAGE TYPE	A		
REQ.	ITEM	PART NO.	DESCRIPTION	SYMBOL		
		.062	THE TECHNICAL MATERIEL CORP.			
		STOCK SIZE	MAMARONECK, NEW YORK			
Q	ORIGINAL RELEASE FOR PRODUCTION	9-1-66	ALUMINUM	PLATE, END		
		Q	RME			
SYM	DESCRIPTION	DATE	CH. NO.	DRAFTS	CHECKER	ENG. APP.
	UNLESS OTHERWISE SPECIFIED DIMENSIONS ARE IN INCHES AND INCLUDE CHEMICALLY APPLIED OR PLATED FINISHES	SCALE	1:2			
			5052	H32	C.E.D. 8-18-66	
			TYPE & TEMPER	HEAT TREAT. SPEC.	DRAWN	CHECKED
			S404 VEL IRIDITE			
			S115 TMC GRAY			
			FINISH & SPEC. NO.	ELEC. DES. APP.	MECH. DES. APP.	
DECIMALS	TOLERANCES	FRACTIONS	CODE			
.X ± .05		± 1/64				
.XX ± .01		ANGLES				
.XXX ± .005		± 0° 30'				
						MS5058 Q