

REQ. PER UNIT 1	USED ON		JJ-196
	MODEL KIT-101	ASS'Y. NO.	

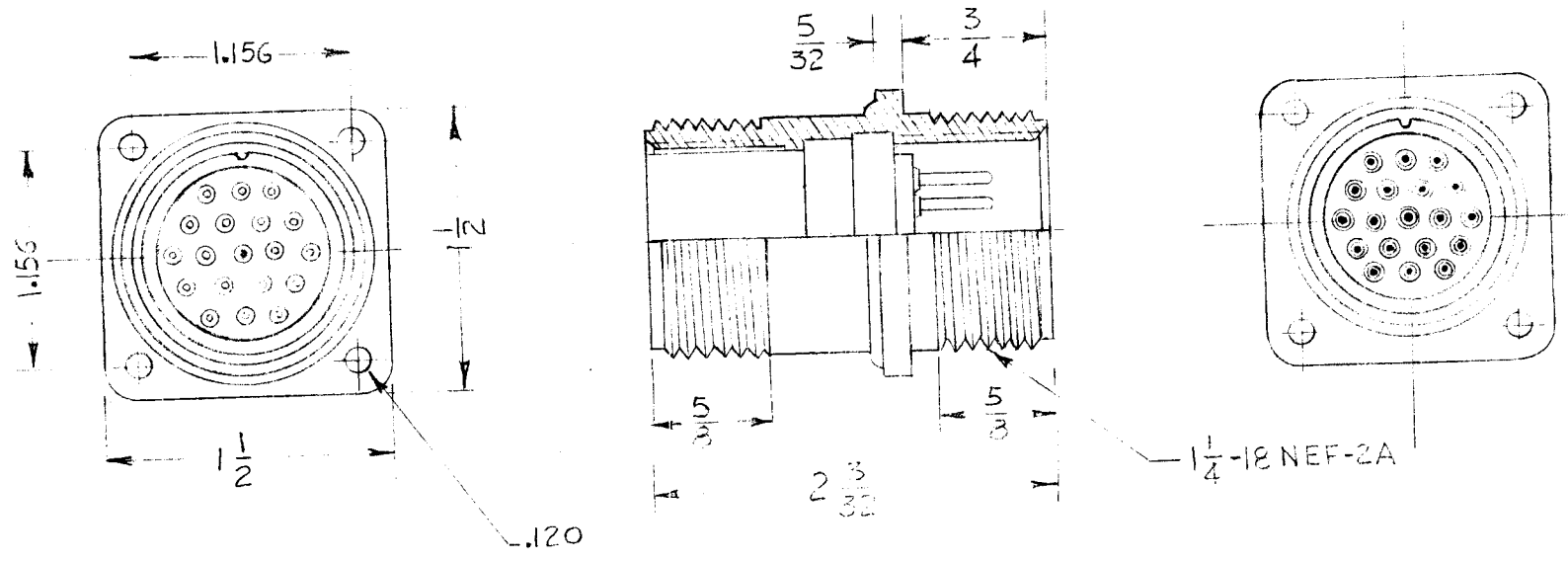

							REQ.	ITEM	PART NO.	DESCRIPTION	SYMBOL					
										THE TECHNICAL MATERIEL CORP.						
										MAMARONECK, NEW YORK						
										ADAPTER, CONNECTOR,						
										BULK HEAD						
ISSUE	ITEM	CHANGED FROM	DATE	CH. NO.	DRAFTS	CHECKER	ENG. APP.			J. Dol	ve	SMA				
TOLERANCES			SCALE: 5/16								DRAWN	CHECKED	FINAL APPROVAL			
DEC. DIM. ±			MAXIMUM ALLOWABLE TOLERANCES HAVE BEEN DETERMINED AND ANY DEVIATIONS WILL BE CAUSE FOR REJECTION. REMOVE ALL BURRS AND SHARP EDGES				TYPE & TEMPER	HEAT TREAT. SPEC.					JJ-196			
FRAC. DIM. ±																
ANGULAR DIM. ±																
							FINISH & SPEC. NO.		ELEC. DES. APP	MECH. DES. APP						