

IF IT IS FOUND DESIRABLE TO CHANGE ANY TOLERANCE OR OTHER DETAIL SPECIFIED ON THIS DRAWING NOTIFY THE PURCHASER PROMPTLY.

MAXIMUM ALLOWABLE TOLERANCES HAVE BEEN DETERMINED AND DEVIATIONS WILL BE CAUSE FOR REJECTION. REMOVE ALL BURRS AND SHARP EDGES

STANDARD DRAWING

JJ-129

TMC No.	CAT. NO	CONTACTS
JJ-129-1	S-302 DB	2
JJ-129-2	S-303 DB	3
JJ-129-3	S-304 DB	4
JJ-129-4	S-306 DB	6
JJ-129-5	S-308 DB	8
JJ-129-6	S-312 DB	12

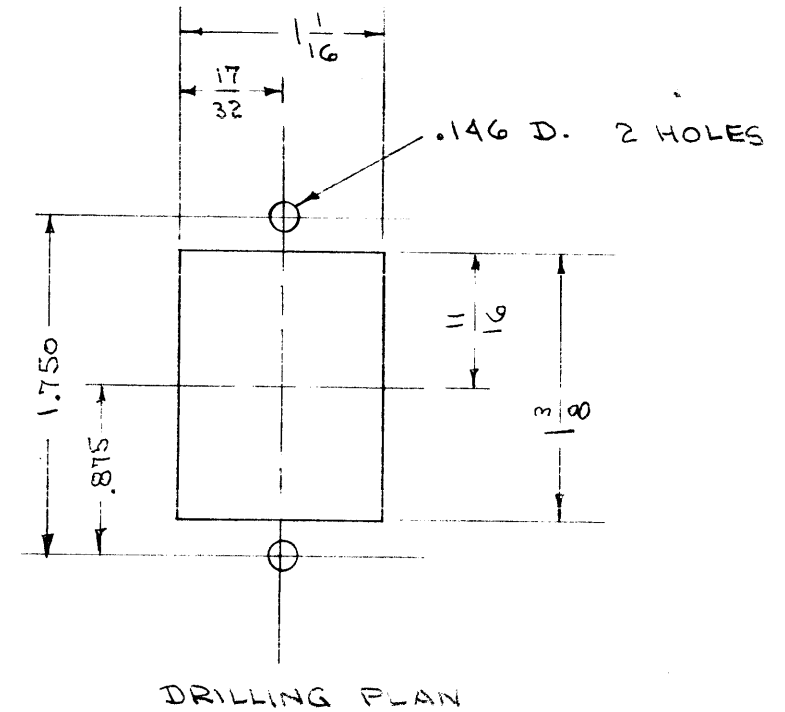
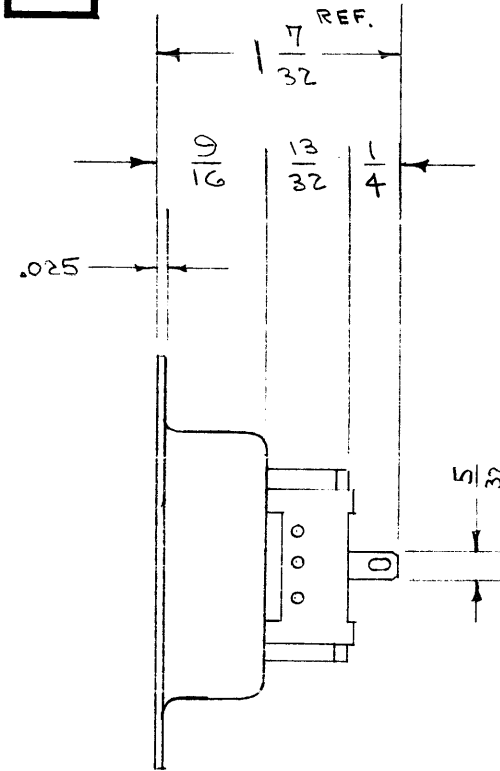
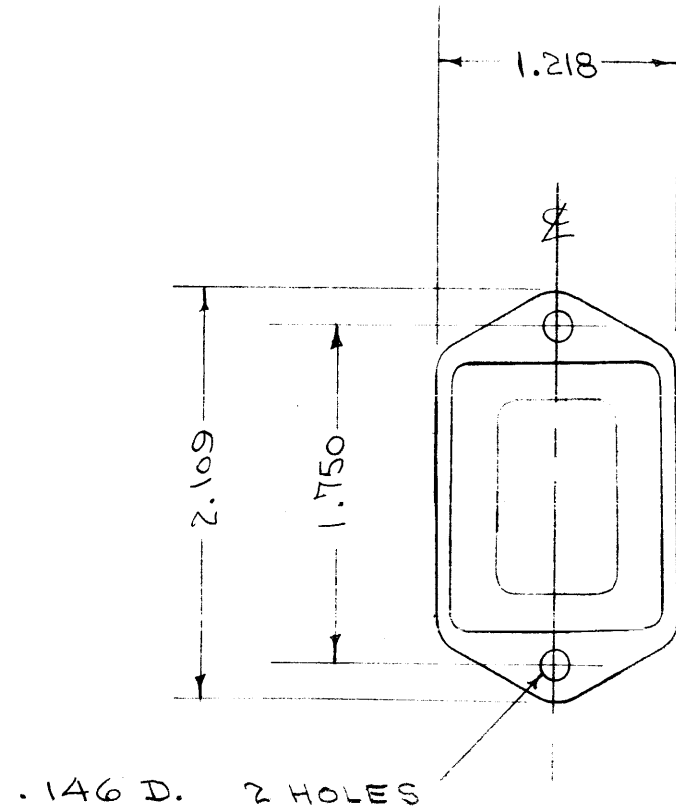

NOTICE TO PERSONS RECEIVING THIS DRAWING

THE TECHNICAL MATERIEL CORPORATION claims proprietary right in the material disclosed hereon. This drawing is issued in confidence for engineering information only and may not be reproduced or used to manufacture anything shown hereon without permission from THE TECHNICAL MATERIEL CORPORATION to the user. This drawing is loaned for mutual assistance and is subject to recall at any time.

Property of:
THE TECHNICAL MATERIEL CORPORATION
 MAMARONECK, NEW YORK

REF: HOWARD B. JONES DIV. - CINCH MFG. CORP.

REQ.	ITEM	PART NO.	DESCRIPTION	SYMBOL
	#		THE TECHNICAL MATERIEL CORP.	
		STOCK SIZE	MAMARONECK. NEW YORK	
	#	#	SOCKET, w/DEEP BRACKET	
		MATERIAL		
		WEIGHT PER PC.		
		TYPE & TEMPER	C.D.D. 11-10-53	
		HEAT TREAT. SPEC.	DRAWN	ELEC. DES. APP. MECH. DES. APP.
		FINISH & SPEC. NO.	CHECKED	FINAL APPROVAL
				JJ-129

ISSUE	ITEM	CHANGED FROM	DATE	CN. NO.	DRAFTS	CHECKER	ENG. APP.
TOLERANCES							
ALL OTHERS				SCALE:			
DEC. DIM. ±				DRILL, PUNCH, COMMERCIAL STOCK			
FRAC. DIM. ±				SIZES AND MANUFACTURERS			
ANGULAR DIM. ±				TOLERANCES ARE NOT INCLUDED.			

MODEL	PROJECT NO.	ASS'Y. NO.	DATE