

STANDARD DRAWING

REQ. PER UNIT	4	USED ON	DATE
MODEL	DDR-5	ASSY. NO.	12-26-63
		FS-124	A

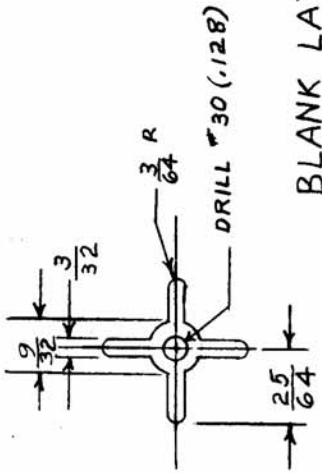

BLANK LAYOUT

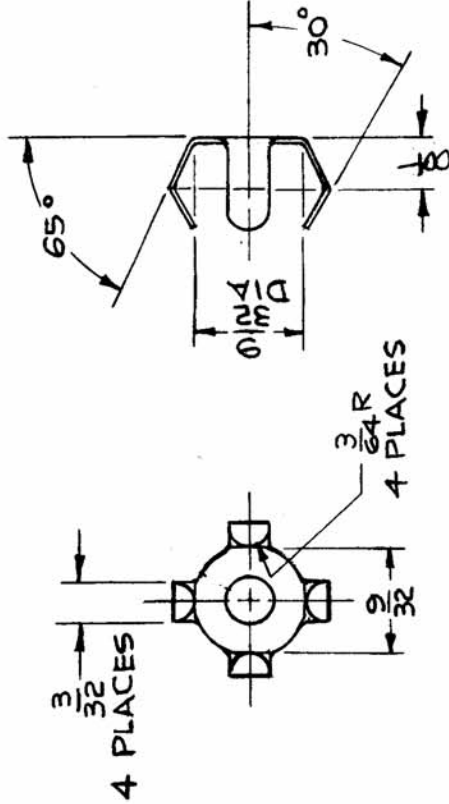

SPECIFICATIONS.

MATERIAL: .015 ± .003 SPRING STEEL
 HEAT TREAT: 600°F FOR 2 HOURS.
 FINISH: TMC S-105 BRIGHT CADMIUM PLATE.

REQ. ITEM	PART NO.	EATON DESCRIPTION	SYMBOL
SEE SPEC	SEE SPEC	THE TECHNICAL MATERIEL CORP. MAMARONECK. NEW YORK	
SEE SPEC	SEE SPEC	FASTENER, MOUNTING	
SEE SPEC	SEE SPEC	MATERIAL	
TYPE & TEMPER	HEAT TREAT. SPEC.	CHECKED	FINAL APPROVAL
SEE SPEC	SEE SPEC	ELEC. DES. APP. MECH. DES. APP.	FS-124 A
FINISH & SPEC. NO.			

SYM	DESCRIPTION	DATE	CH. NO.	DRAFTS	CHECKER	ENG. APP.
A	3/64 R WAS 9/64 R	4-3-64	11161	A.M.	JDL	JC
UNLESS OTHERWISE SPECIFIED DIMENSIONS ARE IN INCHES AND INCLUDE CHEMICALLY APPLIED OR PLATED FINISHES		SCALE		2/1		
TOLERANCES		CODE		S-401-259		
DECIMALS		FRACTIONS		ANGLES		
.X ± .05		± 1/64		± 0° 30'		
.XX ± .01						
.XXX ± .005						