

STANDARD DRAWING

CU-1

IF IT IS FOUND DESIRABLE TO CHANGE ANY TOLERANCE OR OTHER DETAIL SPECIFIED ON THIS DRAWING NOTIFY THE PURCHASER PROMPTLY.

MAXIMUM ALLOWABLE TOLERANCES HAVE BEEN DETERMINED AND DEVIATIONS WILL BE CAUSE FOR REJECTION. REMOVE ALL BURRS AND SHARP EDGES

USED ON PROJECT NO. ASSY. NO. MODEL

| TMC NO. | CAT. NO. | D | E | R | NYLON |
|-----------|----------|-------|-------|------|-------|
| CU-102-1 | 2 | .125 | 0.328 | 1/32 | * |
| CU-102-2 | 3 | .188 | 0.390 | 1/32 | * |
| CU-102-3 | 4 | .250 | 0.421 | 1/32 | * |
| CU-102-4 | 5 | .313 | 0.453 | 1/32 | * |
| CU-102-5 | 6 | .375 | 0.483 | 1/32 | * |
| CU-102-6 | 7 | .438 | 0.531 | 1/32 | * |
| CU-102-7 | 8 | .500 | 0.562 | 1/32 | * |
| CU-102-8 | 9 | .563 | 0.625 | 1/16 | * |
| CU-102-9 | 9 1/4 | .593 | 0.618 | 1/16 | * |
| CU-102-10 | 10 | .625 | 0.610 | 1/16 | * |
| CU-102-11 | 11 | .688 | 0.666 | 1/16 | * |
| CU-102-12 | 12 | .750 | 0.765 | 1/16 | * |
| CU-102-13 | 14 | .875 | 0.812 | 1/16 | * |
| CU-102-14 | 16 | 1.000 | 0.906 | 1/16 | * |
| CU-102-15 | 18 | 1.125 | 0.968 | 1/16 | * |
| CU-102-16 | 19 | 1.188 | 1.025 | 1/16 | * |
| CU-102-17 | 20 | 1.250 | 1.156 | 1/16 | * |
| CU-102-18 | 24 | 1.5 | 1.062 | 1/16 | * |
| CU-102-19 | 32 | 2.0 | 1.312 | 1/16 | * |
| CU-102-20 | 40 | 2.5 | 1.562 | 1/16 | * |
| CU-102-21 | 48 | 3.0 | 1.812 | 1/16 | * |

5/8 WIDE

CU 102 - 3N
TMC NO.

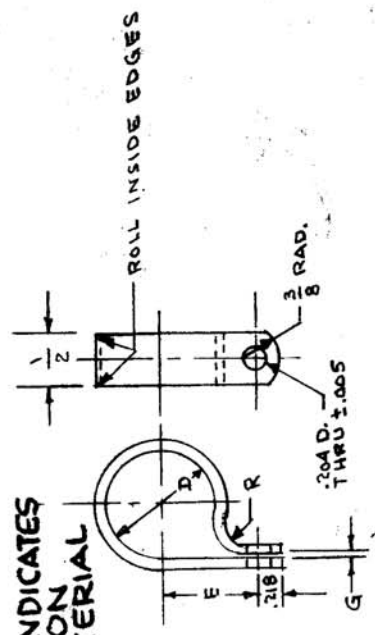

DIMENSIONS FOR REF. ONLY
MATERIAL - ETHYL CELLULOSE EXCEPT AS NOTED
* AVAILABLE IN WHITE NYLON

S401-294
S401-292
S401-293

| | | | |
|--------------------|----------------|--|--------|
| REQ. ITEM | PART NO. | DESCRIPTION | SYMBOL |
| | .062 THK. | THE TECHNICAL MATERIAL CORP. MAMARONECK, NEW YORK | |
| SEE NOTE | STOCK SIZE | CLAMP, "G" TYPE | |
| MATERIAL | WEIGHT PER PC. | | |
| TYPE & TEMPER | | | |
| HEAT TREAT. SPEC. | | | |
| PURCH. & SPEC. NO. | | | |

| | | | | | |
|---|--------------|---------|---------|----------------|-----------|
| ISSUE ITEM | CHANGED FROM | DATE | CN. NO. | DRAFTS CHECKER | ENG. APP. |
| A | | 6-16-64 | 11472 | SRG | |
| TOLERANCES | | | | | |
| DEC. DIM. ± .005 | | | | | |
| FRACTIONAL DIM. ± 1/64 | | | | | |
| ANGULAR DIM. ± | | | | | |
| SCALE | | | | | |
| DRILL, PUNCH, COMMERCIAL STOCK SIZES AND MANUFACTURERS TOLERANCES ARE NOT INCLUDED. | | | | | |

| | | |
|----------|----------|----------------|
| DRAWN | DATE | FINAL APPROVAL |
| WSE wly | 11/19/57 | CU-102 |
| QUANTITY | | |
| | | |