

REQ. PER UNIT	USED ON	MODEL	ASSY. NO.	DATE
2		HLC-1		7-19-63
CA-798 A				

NOTE:

1- ITEM (1) TO BE SOLDERED TO ITEM (2), USE ITEM (3)

2- FOR 70 Ω & 700 Ω CONNECTION, USE CA-809

3- SILVER PLATE ITEM (2) AFTER FORMING

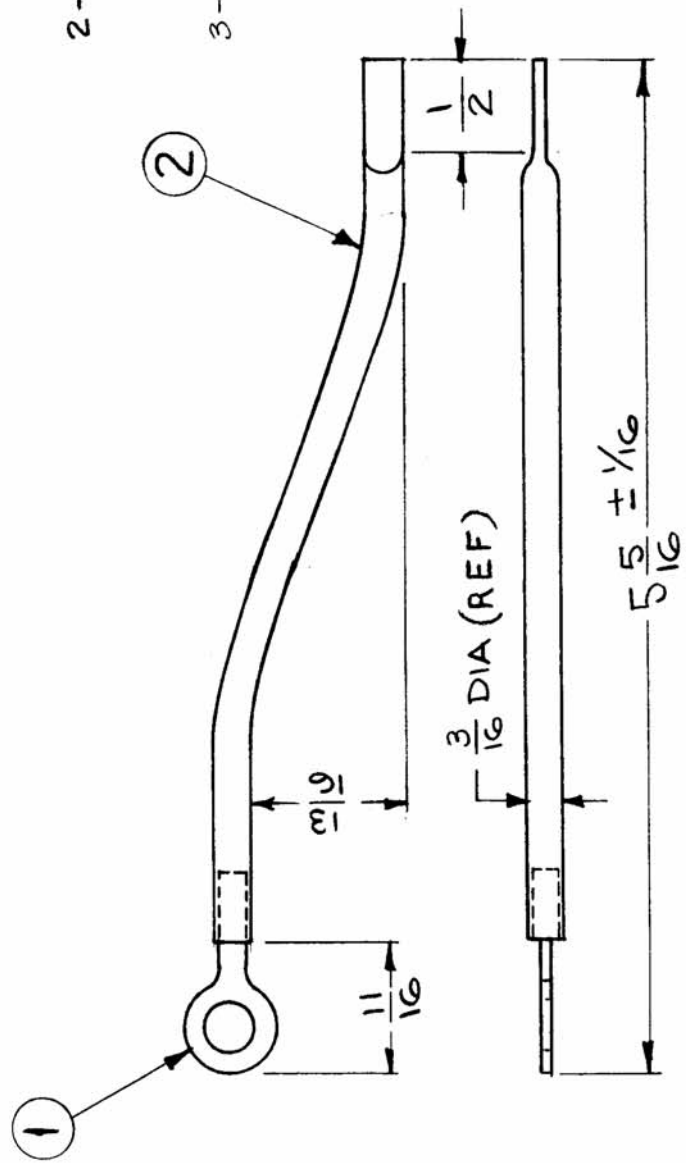

REQ. ITEM	PART NO.	DESCRIPTION	SYMBOL
X 3	BS-101	SOLDER, SILVER	
1	TU-100-3N	TUBE, COPPER	
1	TE-156-32953	TERMINAL, LUG	
		I. JOHNSON	
THE TECHNICAL MATERIEL CORP. MAMARONECK, NEW YORK			
LEAD, ELECTRICAL			
STOCK SIZE			
MATERIAL			
TYPE & TEMPER	HEAT TREAT. SPEC.	DRAWN	CHECKED
5245, S423		<i>J. Green</i>	<i>H.L.</i>
FINISH & SPEC. NO.		FINAL APPROVAL	
		CA-798 A	

DATE	CH. NO.	DRAFTS	CHECKER	ENG. APP.
8.13.64	12131	<i>MB</i>	<i>W.P.</i>	
SCALE NONE				
UNLESS OTHERWISE SPECIFIED DIMENSIONS ARE IN INCHES AND INCLUDE CHEMICALLY APPLIED OR PLATED FINISHES				
TOLERANCES FRACTIONS				
.X ± .05 ± 1/64				
.XX ± .01 ANGLES ± 0° 30'				
.XXX ± .005				