

HOLE	DESCRIPTION	REQ
A	.116 DIA.	10
B	.189 DIA	2

A4250-1

MACHINING

MATERIAL: .062 G11 SILICONE FIBERGLASS
FINISH: GREEN SEMIGLOSS

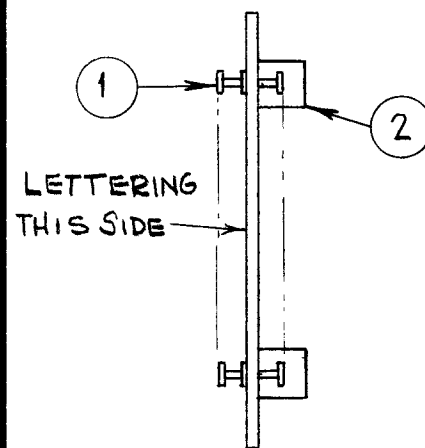

MOUNT ITEM 2 IN "B" HOLES AFTER FINISHING

MOUNT ITEM 1 IN ALL "A" HOLES AFTER FINISHING

A4250-3
SUB-ASS'Y.

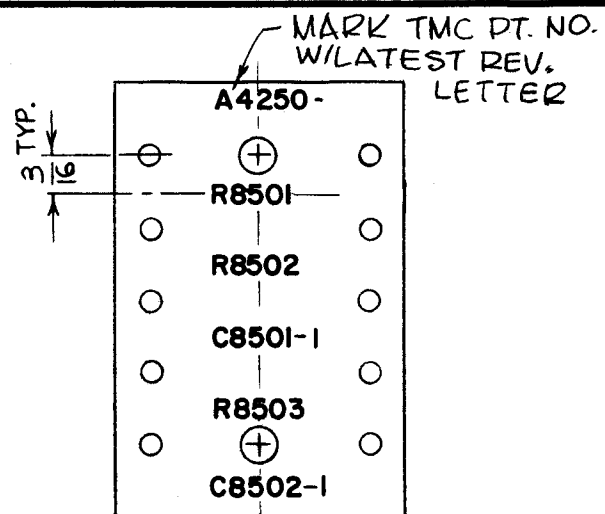

A4250-2
MARKING

MARKING PROCESS:
AS PER TMC SPECIFICATION 8-727.
LETTERING:
^{3/32} HIGH WHITE GOTHIC, LOCATED AS SHOWN.

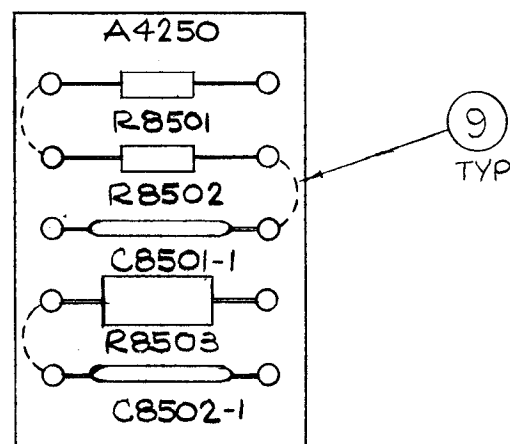

A4250-4
FINAL ASS'Y.

A
A4250

REVISIONS						
SYM	DESCRIPTION	DATE	E.M.N. NO.	DRAFT	CHKD	APPD
X	EXPEDIMENTAL RELEASE	5/11/65	-M	HLA		
XI	ITEM NO.9 ADDED	5/13/65	-M	HLA		
X3	IT4 WAS GF 101K ASSY NO. A4084 ADDED	9/20/65	-M	H.V.	J.P.	J.P.
Ø	ORIGINAL RELEASE FOR PRODUCTION	10/4/65	Ø	H.V.		
A	C8501-1 & C8502-1 WAS C8501 & C8502	10/14/65	14984	H.V.	J.P.	J.P.

REQ'D.	ITEM	PART NUMBER	DESCRIPTION	SYMBOL
X	9	WL100-7	WIRE, ELECTRICAL, BUSS	
X	8	BS100	SOLDER, SOFT	
1	7	CC100-32	CAPACITOR, FIXED, CER	C8502
1	6	CC100-24	CAPACITOR, FIXED, CER	C8501
1	5	RC32GF333K	RESISTOR, FIXED, COMP	R8503
1	4	RC20GF104K	RESISTOR, FIXED, COMP	R8502
1	3	RC20GF473K	RESISTOR, FIXED, COMP	R8501
2	2	TE108-1	STANDOFF, RIVET TYPE	
10	1	TE131-2	TERMINAL, MIDGET, DUE END	

STURMER		LIST OF MATERIAL			
MATERIAL		THE TECHNICAL MATERIEL CORP. MAMARONECK, NEW YORK			
FINISH		TITLE TERMINAL BOARD ASS'Y.			
UNLESS OTHERWISE SPECIFIED DIMENSIONS ARE IN INCHES AND INCLUDE CHEMICALLY APPLIED OR PLATED FINISHES		DRAWN N. AUSTIN	DATE 4-29-65	FINAL APPROVAL [Signature]	DATE 10/14/65
DECIMALS .X ± .05 .XX ± .01 .XXX ± .005		CHECKED [Signature]	DATE 10/4/65	A4250	
FRACTIONS ± 1/64 ANGLES ± 0° 30'		ELECT. DES. [Signature]	DATE 10/4/65	A	
TOLERANCES		MECH. DES. [Signature]	DATE	SHEET	
				REV. LTR.	

NOTES

THE CONTENTS OF THIS DRAWING ARE THE EXCLUSIVE PROPERTY OF THE TECHNICAL MATERIEL CORP. ITS UNAUTHORIZED USE OR REPRODUCTION IN WHOLE OR IN PART IS STRICTLY FORBIDDEN.