

HOLE	DESCRIPTION	REQ
A	.062-.065 DIA.	3
B	.187 DIA.	3

A3529

REVISIONS					
SYM	DESCRIPTION	DATE	E.M.N. NO.	DRAFT	CHKD APPD
X	EXPERIMENTAL RELEASE	5-14-64		dh	
X1	REDRAWN & REVISED	7-29-64		G.D.L	
X2	DESCRIPTION HOLES & DIMENSIONS ADDED	8-4-64		G.D.L	
Ø	ORIGINAL RELEASE FOR PRODUCTION	9-11-64		92	

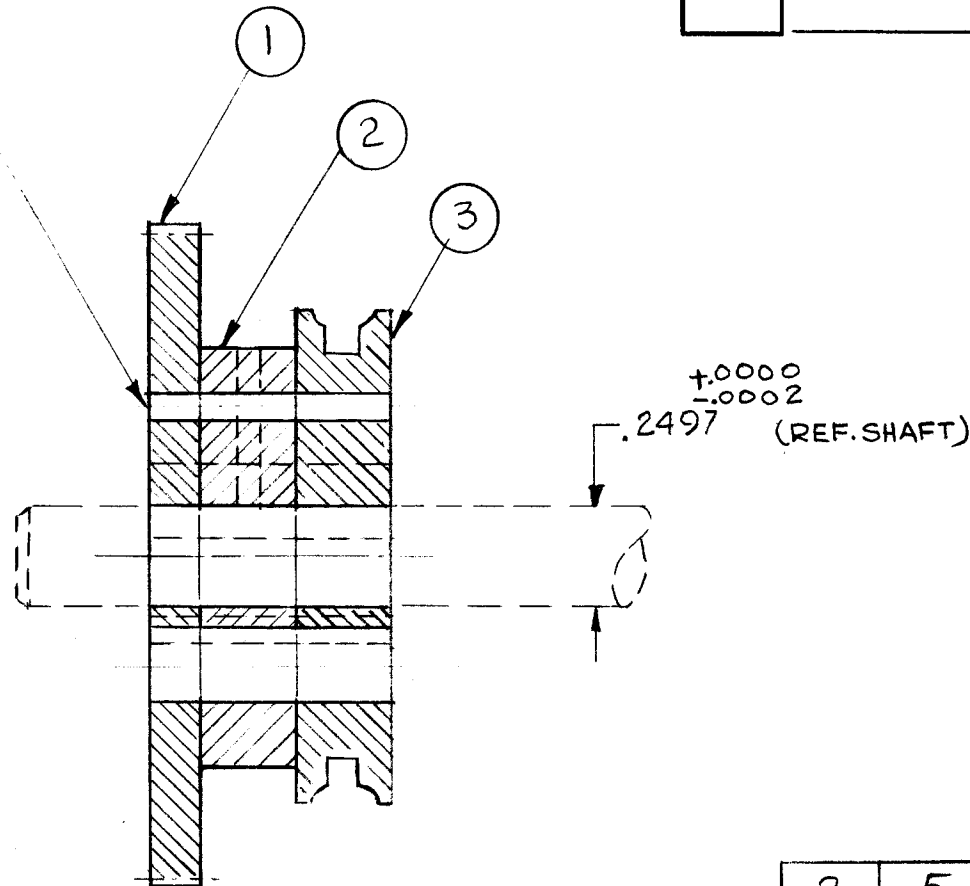
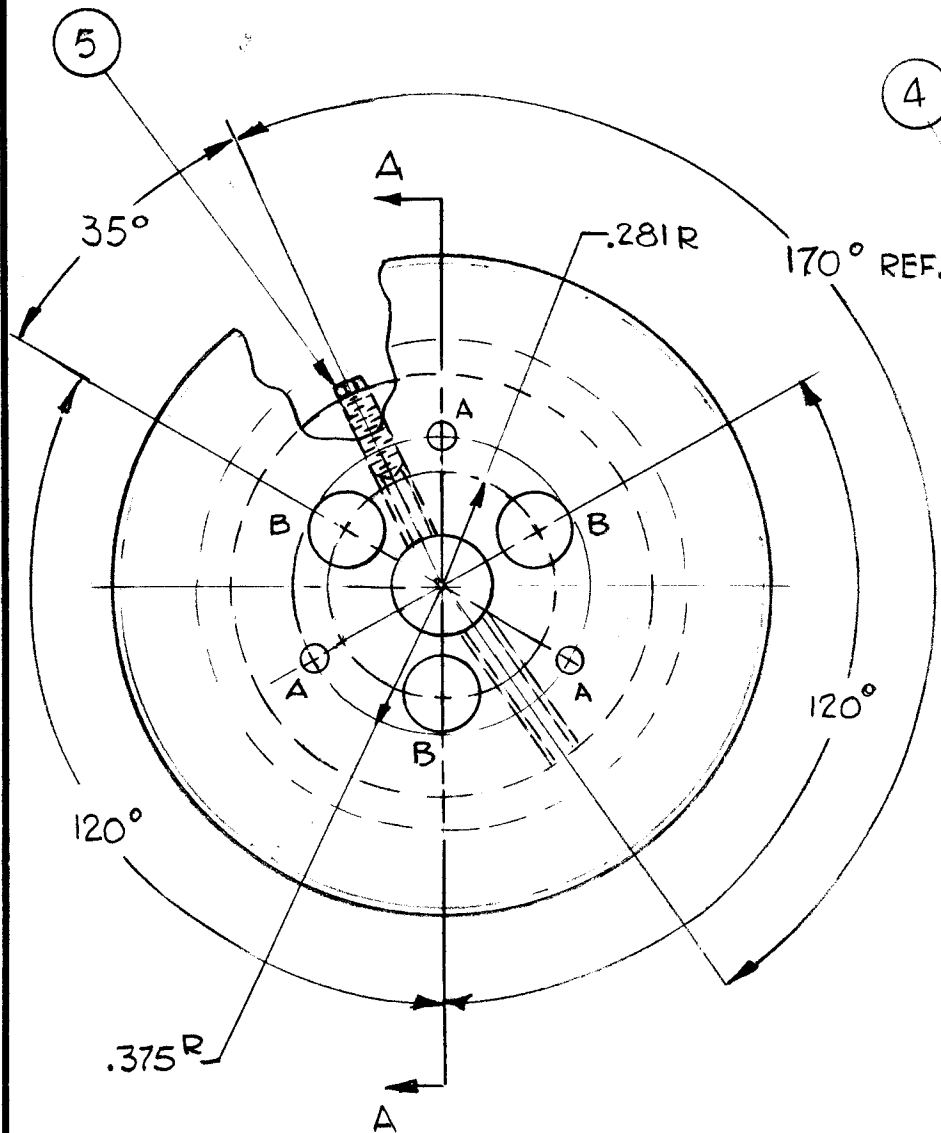

NOTE:  
 1-LINE UP ITEMS 1, 2, AND 3 WITH .2497 DIA. SHAFT  
 2- DRILL HOLES "A" & "B"  
 3-PIN THROUGH "A" HOLES WITH ITEM 4

REQ'D.	ITEM	PART NUMBER	DESCRIPTION	SYMBOL
2	5	SLHC0632SS4	SET SCREW	
3	4	PN59.062-10	PIN, SPRING	
1	3	PM1043	SPROCKET	
1	2	PM1031	PLATE, SPACER	
1	1	GR204	GEAR, SPUR	

T. KRUY LIST OF MATERIAL			
MATERIAL		THE TECHNICAL MATERIEL CORP. MAMARONECK, NEW YORK	
FINISH		TITLE GEAR & SPROCKET ASS'Y	
UNLESS OTHERWISE SPECIFIED DIMENSIONS ARE IN INCHES AND INCLUDE CHEMICALLY APPLIED OR PLATED FINISHES		DRAWN G.D.L	DATE 7-29-64
DECIMALS .X ± .05 .XX ± .01 .XXX ± .005		CHECKED @	DATE
FRACTIONS ± 1/64 ANGLES ± 0° 30'		ELECT. DES. J. Kroy	DATE
TOLERANCES		MECH. DES. J. Kroy	DATE
SCALE 2:1		FINAL APPROVAL A3529	
CODE A		SHEET	
ASS'Y. NO.		REV. LTR. Ø	

1	HFRR-2	
1	HFR-2	
Q'TY./UNIT	MODEL USED ON	ASS'Y. NO.
SCALE 2:1	CODE A	
THE CONTENTS OF THIS DRAWING ARE THE EXCLUSIVE PROPERTY OF THE TECHNICAL MATERIEL CORP. ITS UNAUTHORIZED USE OR REPRODUCTION IN WHOLE OR IN PART IS STRICTLY FORBIDDEN.		

NOTES